

8

7

6

5



4

3

2

1

NOTES:

- 1. BAG AND TAG ALL PARTS.
- 2. USE WITH P/N 7853109-03,

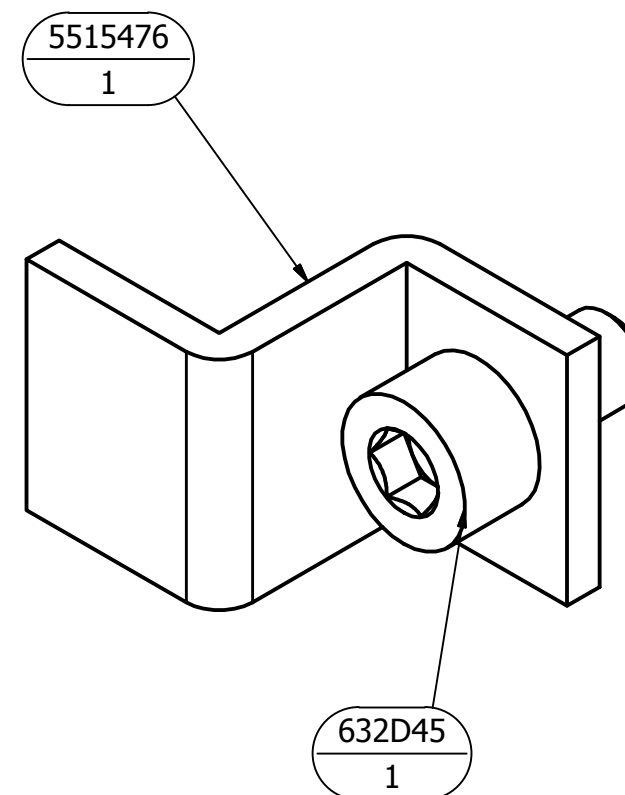
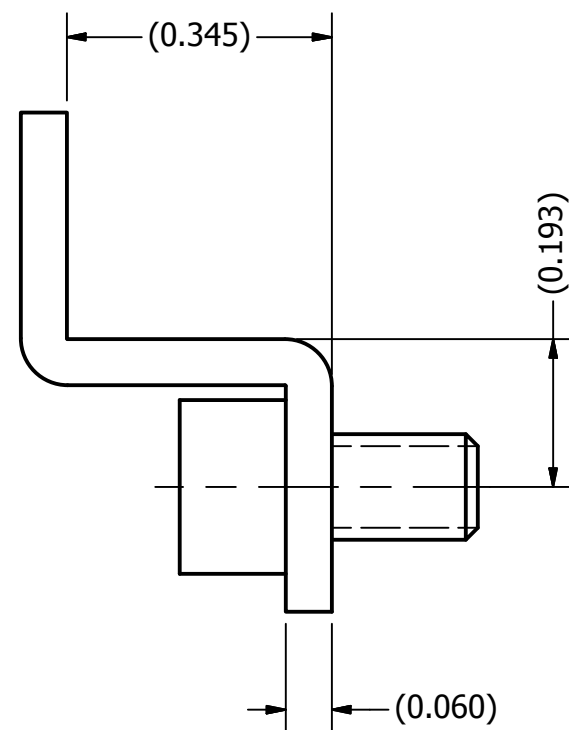
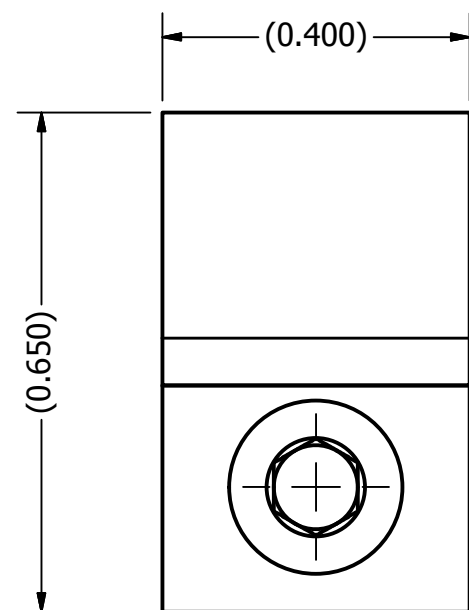

BALLOON LEGEND

PART NUMBER	QTY

TOLERANCES (UNLESS OTHERWISE SPECIFIED)

SHEET METAL		MACHINED	
ANGLES ± 1'	ANGLES ± 1'	.XX ± .03	.XX ± .01
.XXX ± .010	.XXX ± .005	.XXX ± .010	.XXX ± .005
		.XXXX ± .0005	.XXXX ± .0005

REMOVE ALL BURRS AND BREAK SHARP EDGES.

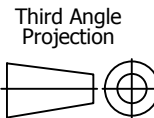

DRAWN BY	
ENGINEERING	
OPERATIONS	
MANUFACTURING	
ASSEMBLY	
MATERIAL USED	

MAC PANEL COMPANY - HIGH POINT, NC

TITLE
**STRAIN RELIEF CLIP ASSY,RCVR,96 HDI
 HEADER (FOR 7853109-03)**

SIZE B	DWG NO 753001SR-09-CU	REV B
------------------	---------------------------------	-----------------

SCALE: SPN: SHEET 1 OF 1

8

7

6

5



4

3

2

1