

NOTES:

1. -

REVISION HISTORY			
REV	DESCRIPTION	DATE	APPROVED
C	ECN #2191 (COMPLETE REDESIGN)	1/8/2008	WKM
D	ECN#3216 NOTED LABEL LOCATION	9/8/2014	GAC
E	ECN 4136 - P/N 97526A125 WAS 632D45	06/20/17	RJH

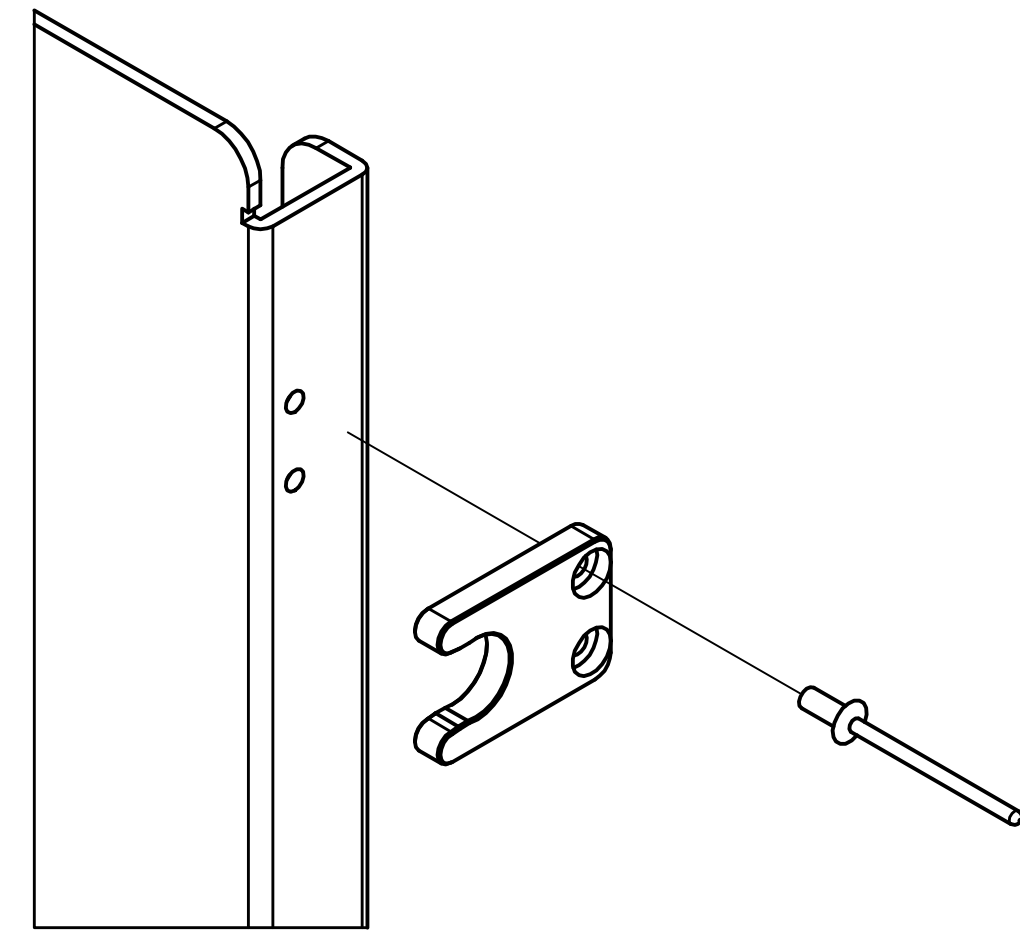

RIVET INSTALLATION REFERENCE

<E>

97526A125	5512068
8	4

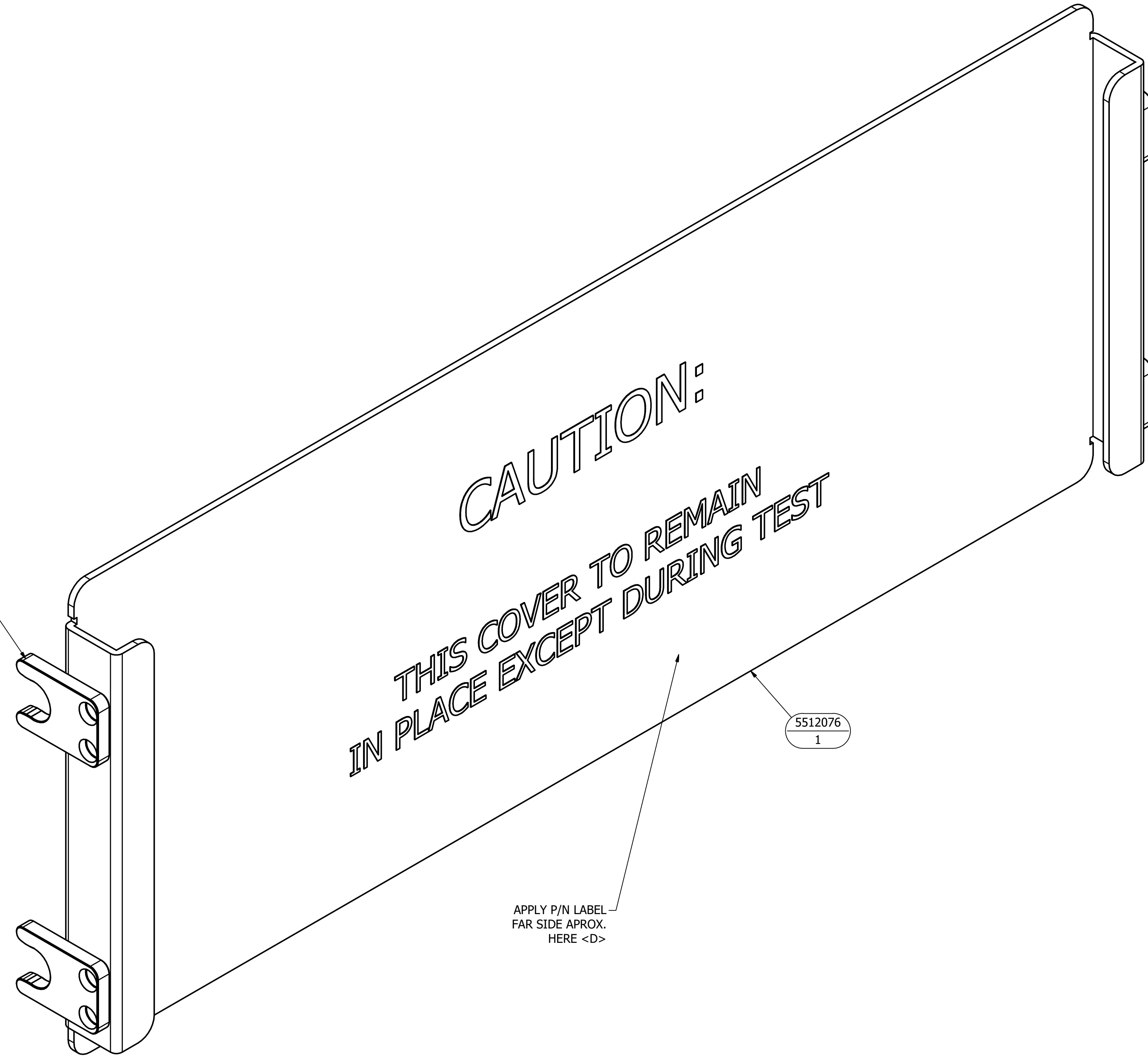

CAUTION:
 THIS COVER TO REMAIN
 IN PLACE EXCEPT DURING TEST

5512076
1

APPLY P/N LABEL
 FAR SIDE APROX.
 HERE <D>

BALLOON LEGEND

PART NUMBER
QTY

TOLERANCES (UNLESS OTHERWISE SPECIFIED)

SHEET METAL	MACHINED
ANGLES ± 1°	ANGLES ± 1°
.XX ± .03	.XX ± .01
.XXX ± .010	.XXX ± .005
	.XXXX ± .0005

REMOVE ALL BURRS AND BREAK SHARP EDGES.

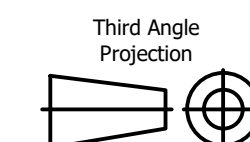

DRAWN BY L.E. CHAPMAN ENGINEERING	06/02/1995	MAC PANEL COMPANY - HIGH POINT, NC	
OPERATIONS		TITLE	
MANUFACTURING		PROTECTIVE COVER, ITA, SERIES 64	
ASSEMBLY		SIZE D	DWG NO 7064P01
MATERIAL USED		SCALE	SPN:

NOTES:

1. -

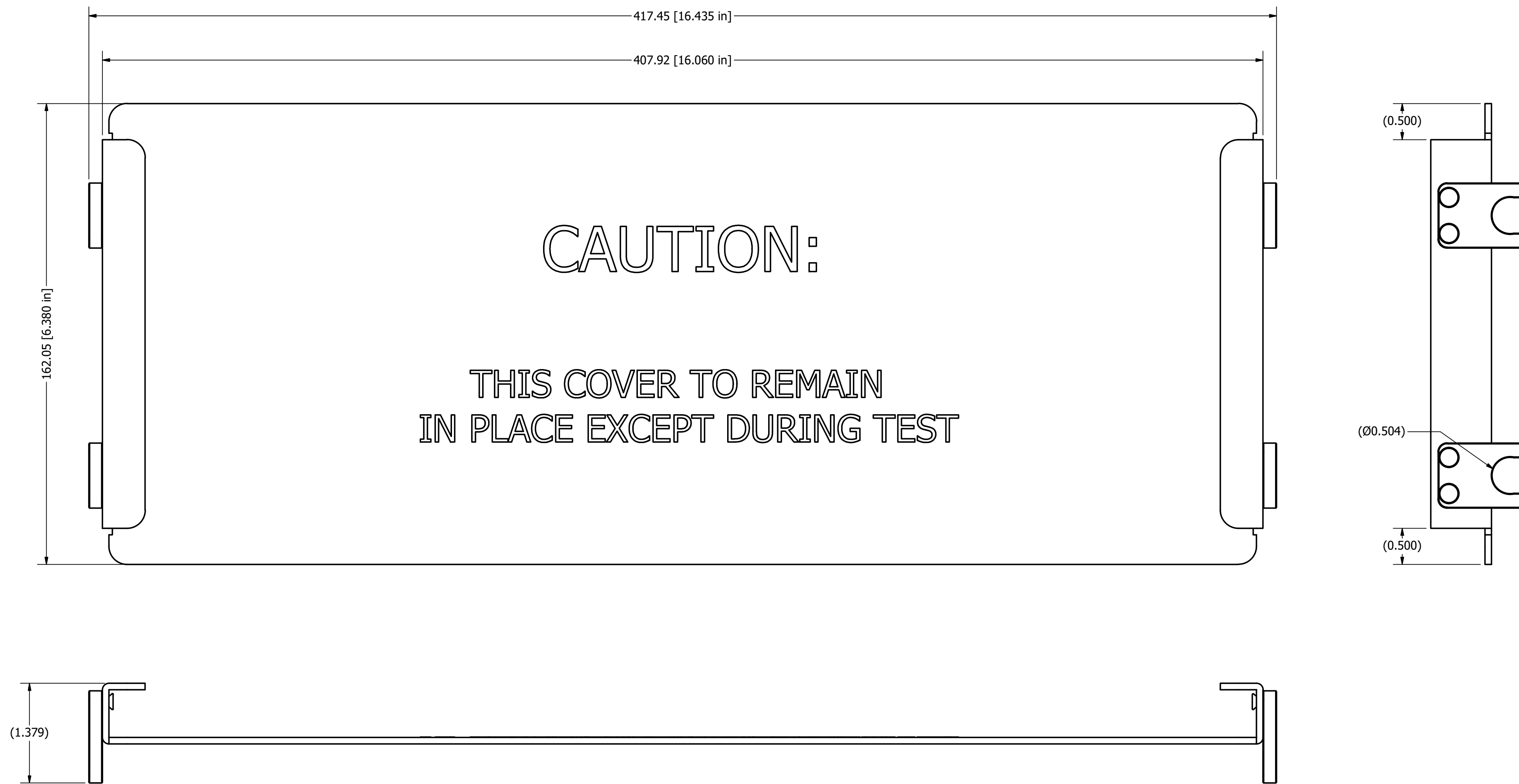

BALLOON LEGEND
PART NUMBER
QTY

TOLERANCES (UNLESS OTHERWISE SPECIFIED)	
SHEET METAL	MACHINED
ANGLES ± 1°	ANGLES ± 1°
.XX ± .03	.XX ± .01
.XXX ± .010	.XXX ± .005
	.XXXX ± .0005
REMOVE ALL BURRS AND BREAK SHARP EDGES.	

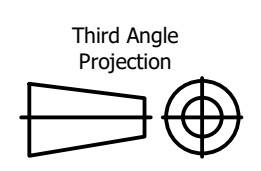

DRAWN BY L.E. CHAPMAN ENGINEERING	06/02/1995	MAC PANEL COMPANY - HIGH POINT, NC	
OPERATIONS		TITLE	
MANUFACTURING		PROTECTIVE COVER, ITA, SERIES 64	
ASSEMBLY		SIZE D	DWG NO 7064P01
MATERIAL USED		SCALE	SPN:
			SHEET 2 OF 2