

NOTES:

1. USE ASSEMBLY INSTRUCTIONS IN9110 FOR ATTACHING DAK TO PXI CARD
2. RECEIVER/ITA MODULE TO BE KEYED ON RIGHT SIDE.
3. MATING ITA MODULE 561403
4. SUPPLIED WITH MOUNTING HARDWARE.
5. SEE SHEET 2 FOR WIRE LIST.

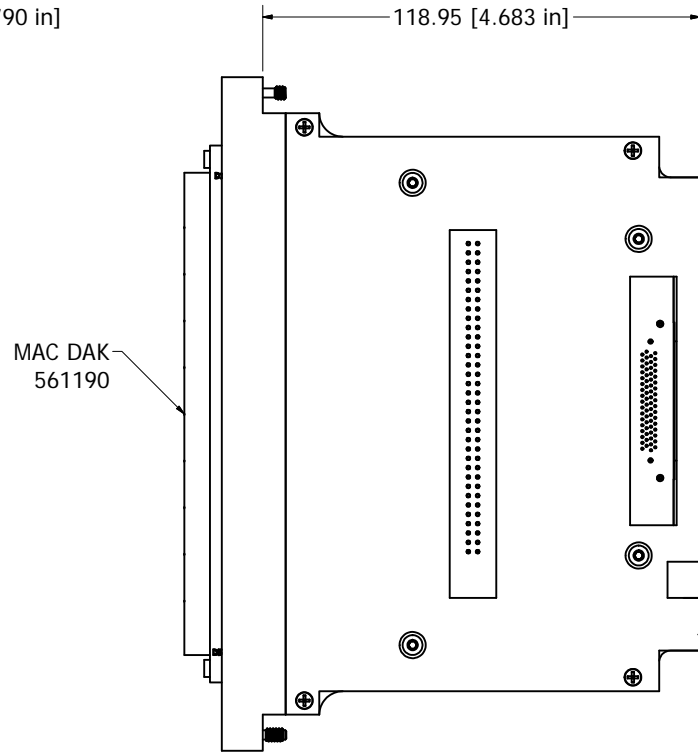

RIGHT SIDE PLATE REMOVED FOR CLARITY.

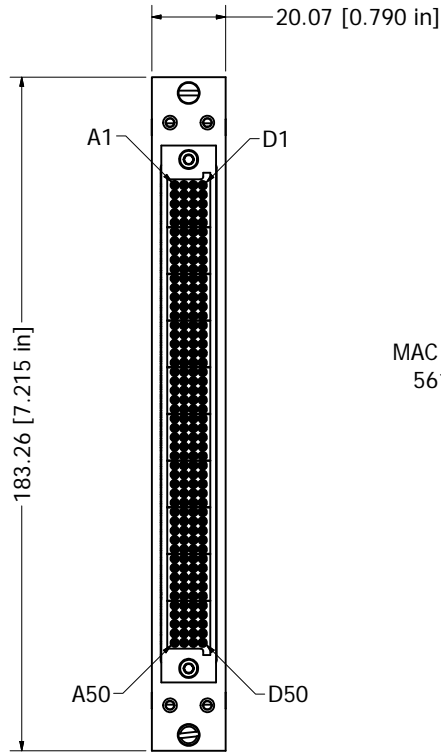
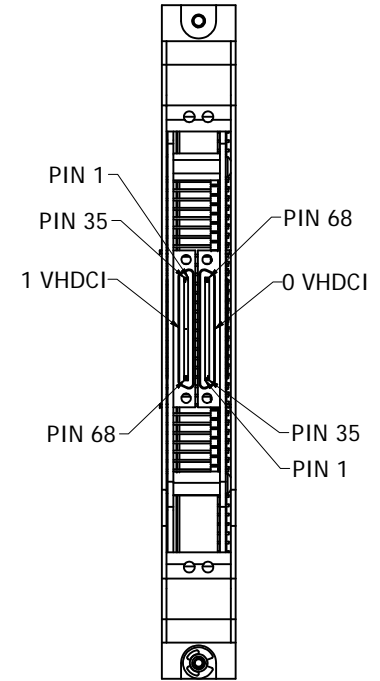

BALLOON LEGEND	
PART NUMBER	QTY

MAC PANEL PROPRIETARY This document may contain confidential and proprietary information that is the property of MAC Panel Company that may not be disclosed to, or duplicated for others except as authorized by MAC Panel Company.		DRAWN BY DBC	20/03/2008	MAC PANEL COMPANY - HIGH POINT, NC
TOLERANCES (UNLESS OTHERWISE SPECIFIED) SHEET METAL MACHINED		OPERATIONS		TITLE DAK ASSY',NI, PCB 68P DOUBLE STACK CONN
ANGLES ± 1°	ANGLES ± 1°	MANUFACTURING		SIZE C
.XX ± .03 .XXX ± .010	.XX ± .01 .XXX ± .005 .XXXX ± .0005	ASSEMBLY		
REMOVE ALL BURRS AND BREAK SHARP EDGES.		MATERIAL USED -		DWG NO 561190-cu
		SCALE 1/1		SPN: SIMILAR P/N
		SHEET 1 OF 2		

NOTES:

1. USE ASSEMBLY INSTRUCTIONS IN9110 FOR ATTACHING DAK TO PXI CARD
2. RECEIVER/ITA MODULE TO BE KEYED ON RIGHT SIDE.
3. MATING ITA MODULE 561403
4. SUPPLIED WITH MOUNTING HARDWARE.
5. SEE SHEET 2 FOR WIRE LIST.

MAC DAK 561190	0 VHDCI	MAC DAK 561190	0 VHDCI	MAC DAK 561190	1 VHDCI	MAC DAK 561190	1 VHDCI
A 1	68	B 1	34	C 1	1	D 1	35
A 2	67	B 2	33	C 2	2	D 2	36
A 3	66	B 3	32	C 3	3	D 3	37
A 4	65	B 4	31	C 4	4	D 4	38
A 5	64	B 5	30	C 5	5	D 5	39
A 6	63	B 6	29	C 6	6	D 6	40
A 7	62	B 7	28	C 7	7	D 7	41
A 8	61	B 8	27	C 8	8	D 8	42
A 9	60	B 9	26	C 9	9	D 9	43
A 10	59	B 10	25	C 10	10	D 10	44
A 11	58	B 11	24	C 11	11	D 11	45
A 12	57	B 12	23	C 12	12	D 12	46
A 13	56	B 13	22	C 13	13	D 13	47
A 14	55	B 14	21	C 14	14	D 14	48
A 15	54	B 15	20	C 15	15	D 15	49
A 16	53	B 16	19	C 16	16	D 16	50
A 17	52	B 17	18	C 17	17	D 17	51
A 18	51	B 18	17	C 18	18	D 18	52
A 19	50	B 19	16	C 19	19	D 19	53
A 20	49	B 20	15	C 20	20	D 20	54
A 21	48	B 21	14	C 21	21	D 21	55
A 22	47	B 22	13	C 22	22	D 22	56
A 23	46	B 23	12	C 23	23	D 23	57
A 24	45	B 24	11	C 24	24	D 24	58
A 25	44	B 25	10	C 25	25	D 25	59
A 26	43	B 26	9	C 26	26	D 26	60
A 27	42	B 27	8	C 27	27	D 27	61
A 28	41	B 28	7	C 28	28	D 28	62
A 29	40	B 29	6	C 29	29	D 29	63
A 30	39	B 30	5	C 30	30	D 30	64
A 31	38	B 31	4	C 31	31	D 31	65
A 32	37	B 32	3	C 32	32	D 32	66
A 33	36	B 33	2	C 33	33	D 33	67
A 34	35	B 34	1	C 34	34	D 34	68

BALLOON LEGEND	
PART NUMBER	QTY

MAC PANEL PROPRIETARY This document may contain confidential and proprietary information that is the property of MAC Panel Company that may not be disclosed to, or duplicated for others except as authorized by MAC Panel Company.		DRAWN BY DBC ENGINEERING	20/03/2008	MAC PANEL COMPANY - HIGH POINT, NC
TOLERANCES (UNLESS OTHERWISE SPECIFIED) SHEET METAL MACHINED ANGLES ± 1° ANGLES ± 1° XX ± .03 XX ± .01 .XXX ± .010 .XXX ± .005 .XXXX ± .0005 REMOVE ALL BURRS AND BREAK SHARP EDGES.		OPERATIONS MANUFACTURING ASSEMBLY MATERIAL USED -	Third Angle Projection 	TITLE DAK ASSY',NI, PCB 68P DOUBLE STACK CONN
		SIZE C	DWG NO 561190-cu	B
		SCALE 1/1	SPN: SIMILAR P/N	SHEET 2 OF 2