

Procedure for mounting a MAC Panel Sliding Shelf assembly into a 3rd party 19" rack.

You will need :

- A standard 19" rack.
- MAC Panel Sliding Shelf assembly of correct size. (see website for details)
- MAC Panel SCOUT Receiver pre assembled to PXI Chassis via MAC Panel Flange Kit.

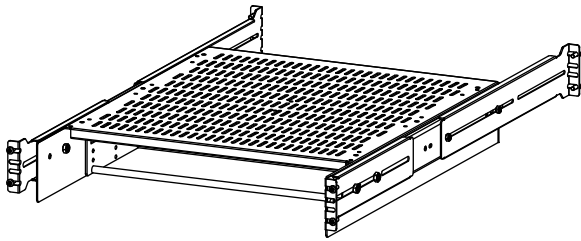

Shelf Assembly
(#561252 shown)

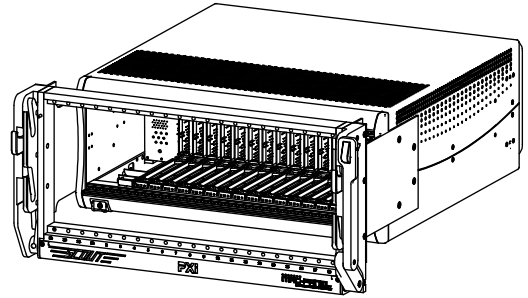

Receiver fastened to Chassis

Detach the support brackets and outer slider from the shelf as follows.

Step 1) Slide the front/rear support & outer runner assembly back until the release clip (shown in picture) in the inner runner becomes visible.

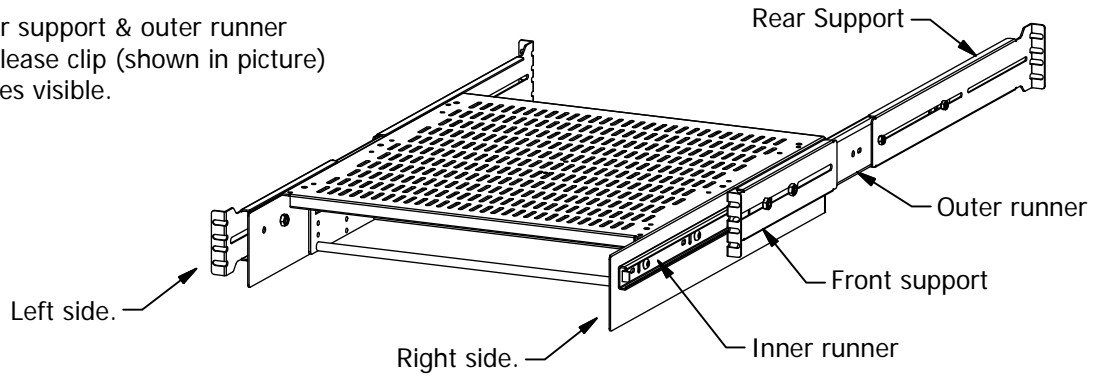

Step 2) Depending the side being removed, either lift or depress the release clip. The front/rear support & outer runner assembly can now be fully removed from the shelf. Repeat this process on the other side.

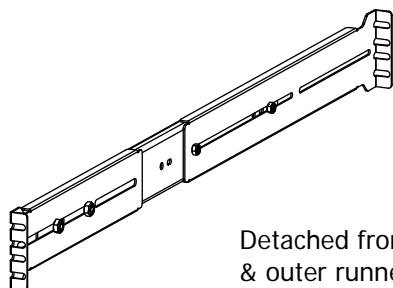

Detached front/rear support
& outer runner assembly.



Release
Clip

Mounting Positions.

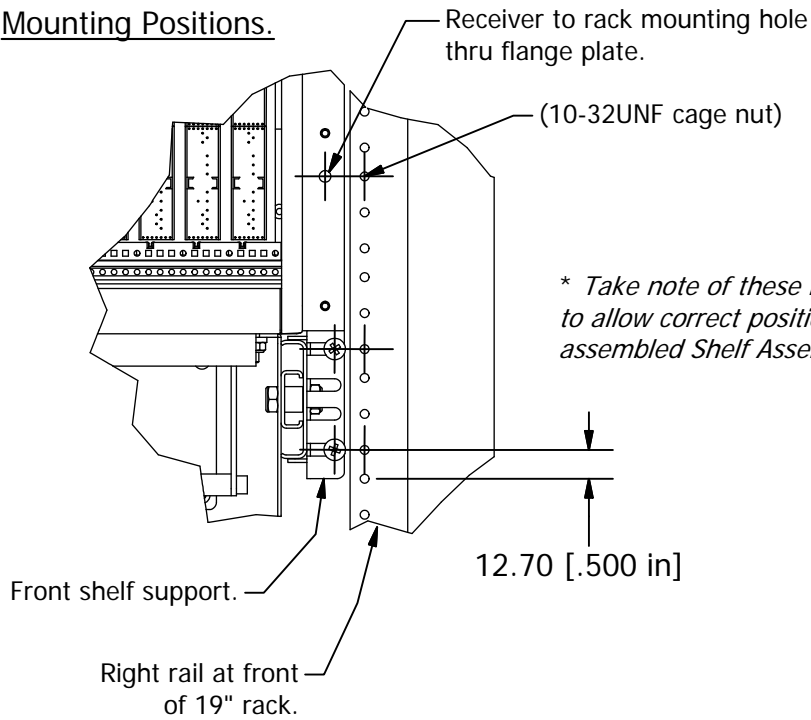

** Take note of these mounting positions before proceeding to Step 3 to allow correct position of Receiver Assembly when placed on fully assembled Shelf Assembly. **

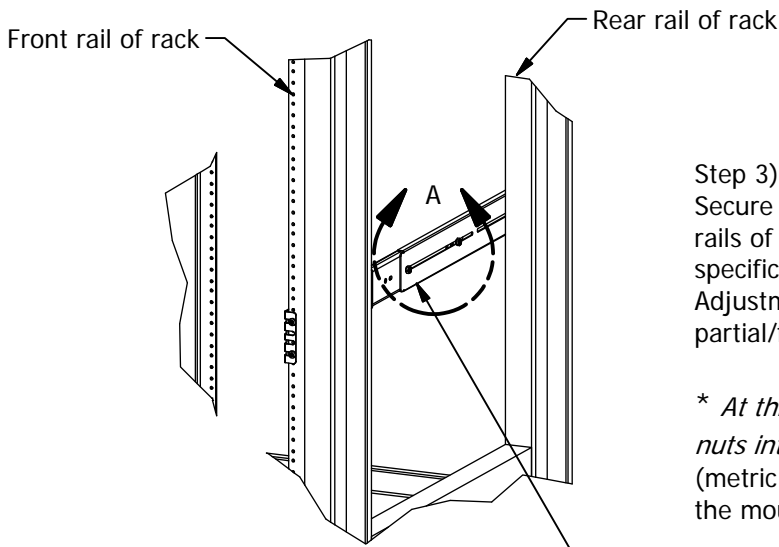

Step 3) Using the above dimensions as a guide. Secure the slide assembly to the front and back rails of the 19" rack using the screws provided or specific screws and cage nuts. Adjustment may be required by either loosening or partial/full disassembly of the runner assembly.

** At this point it is advisable to install a 10-32UNF cage nuts into the hole shown in the Mounting Positions Diagram **
(metric alternative to 10-32UNF can be used at this point, the mounting screw in the receiver must be changed also)

DETAIL A

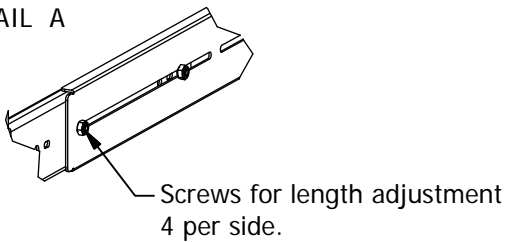

** Longer support must go to the rear of the rack **

Repeat Step 3 on the other side of the rack, making sure left and right runner assemblies are at the same height.

Step 4) Slide the shelf assembly back into the runners, re-engaging the release clips as you do so.

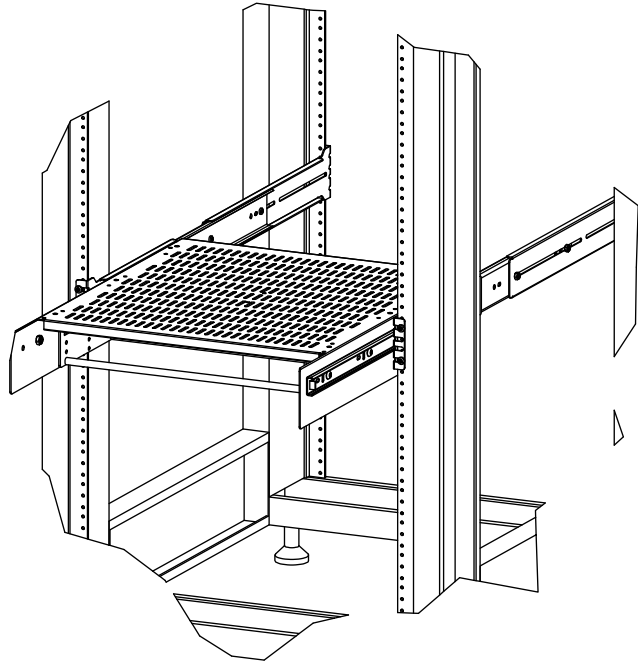

Step 5) The SCOUT Receiver / PXI Chassis combination can now be placed on the shelf assembly.

** Feet should be removed from bottom of chassis **

The whole system can then be slid back and secured to the cage nuts in the front of the 19" rack via the screws through the receiver.

** Once seated the chassis can be secured to the shelf through the vacant feet holes if required **

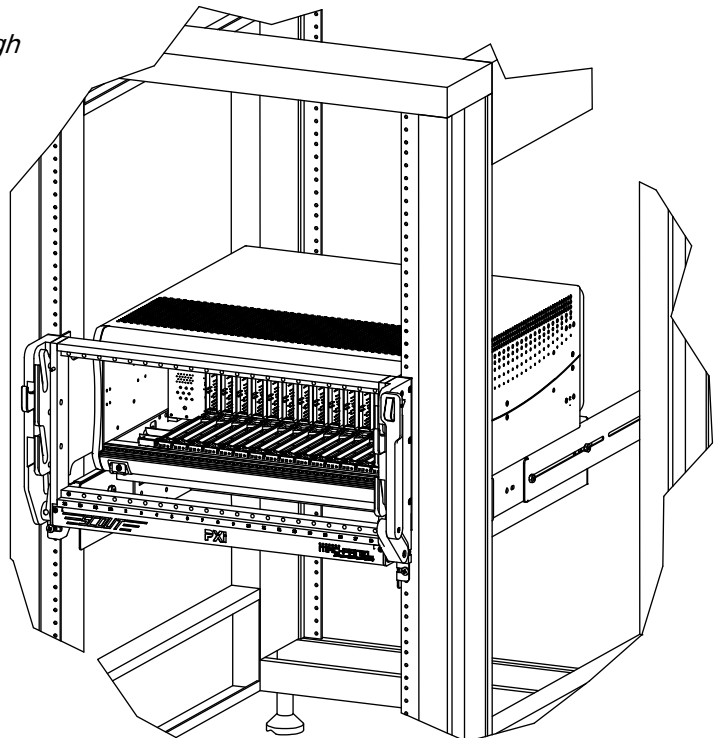

The SCOUT Receiver is now properly secured in the 19" rack and is ready for use.