

NOTES:

1. BAG AND TAG 632D45 (12)

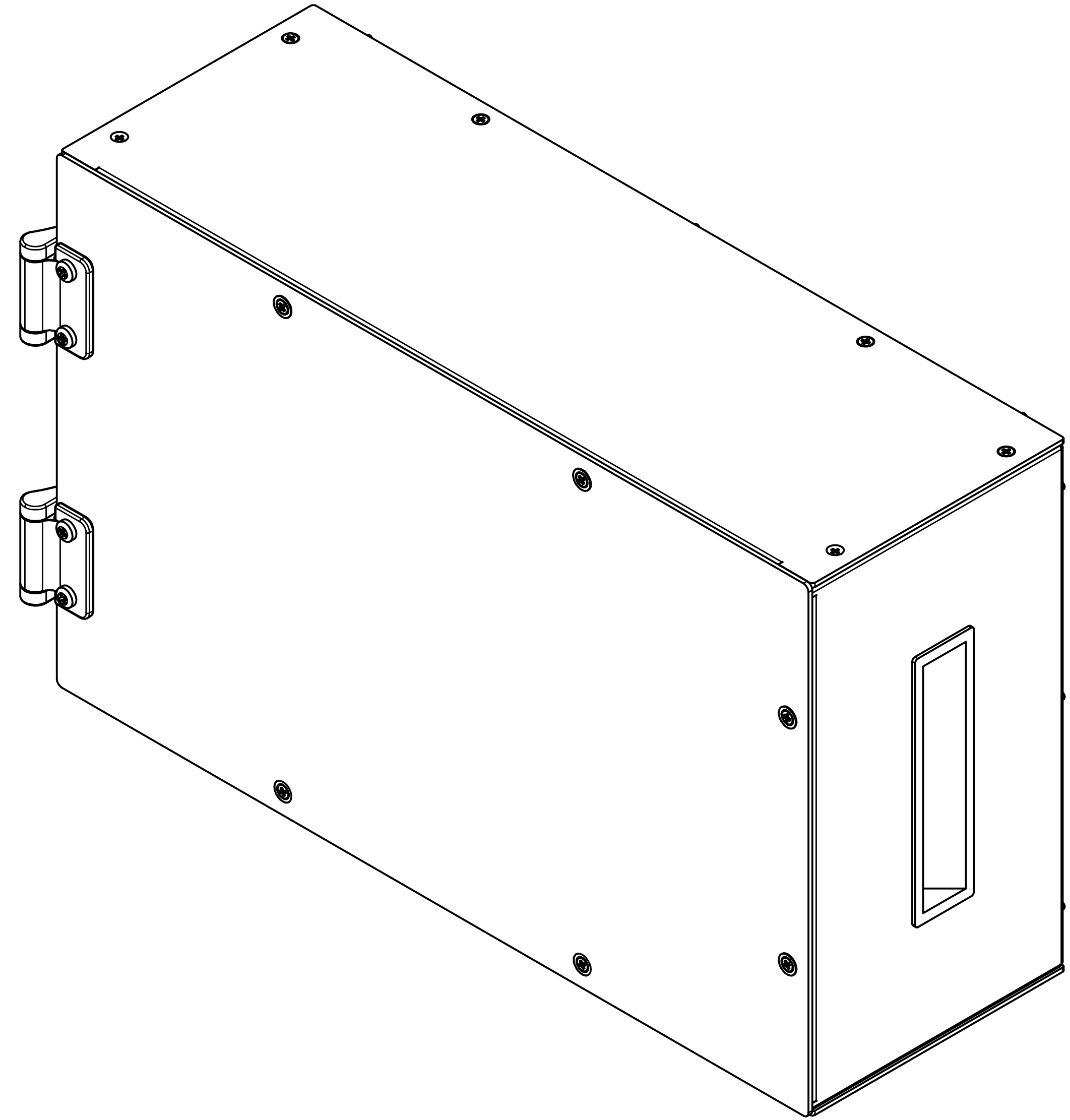
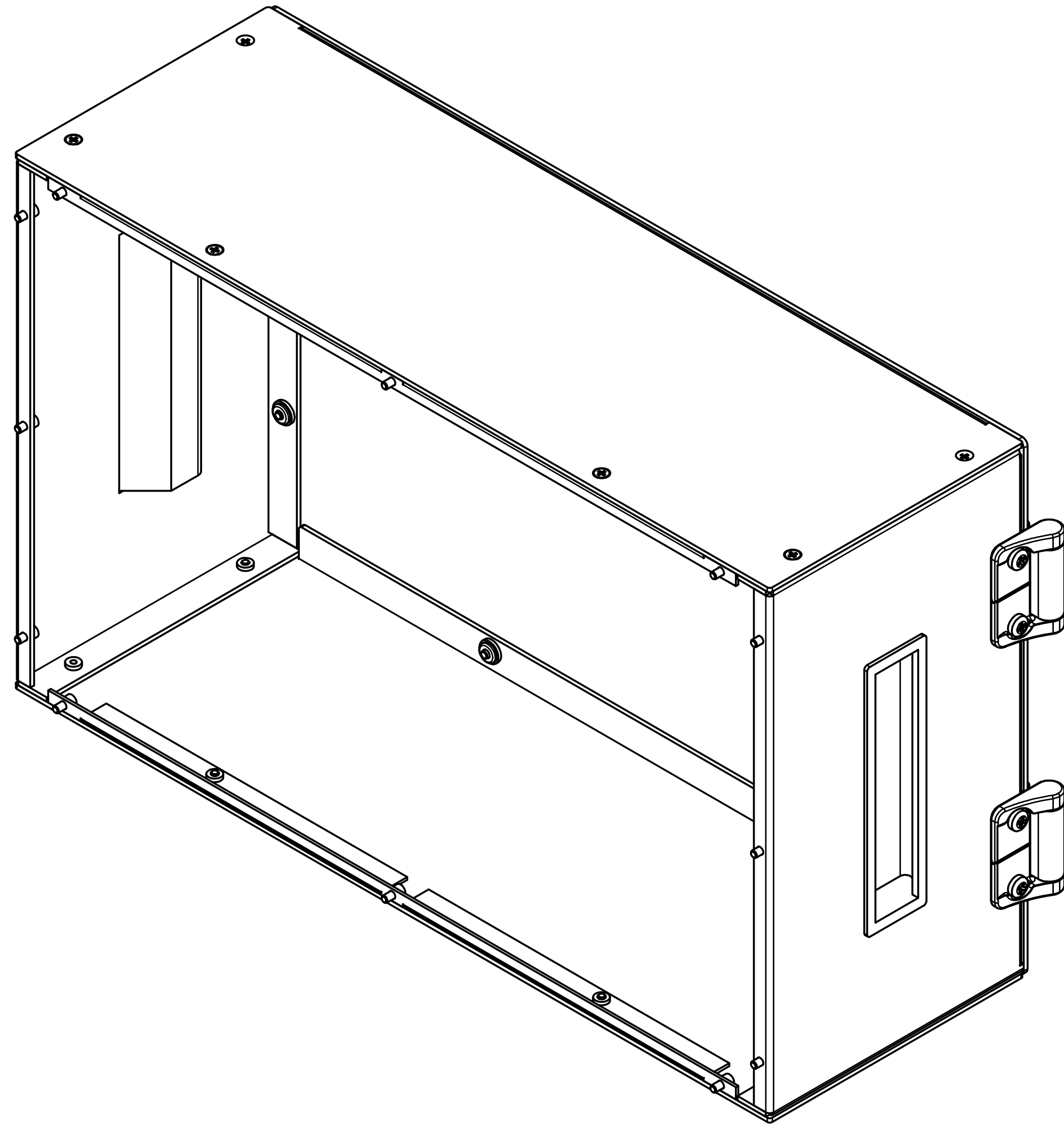

BALLOON LEGEND	
PART NUMBER	QTY

TOLERANCES (UNLESS OTHERWISE SPECIFIED)  
 SHEET METAL MACHINED  
 ANGLES ± 1° ANGLES ± 1°  
 .XX ± .03 .XX ± .01  
 .XXX ± .010 .XXX ± .005  
 .XXXX ± .0005  
 REMOVE ALL BURRS AND BREAK SHARP EDGES.

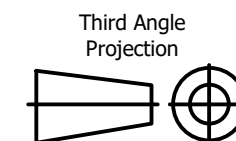

DRAWN BY DBCooper	20/08/2018	MAC PANEL COMPANY - HIGH POINT, NC	
ENGINEERING		TITLE	
OPERATIONS		21 SLOT SCOUT XT, ENCL 6" DP, LH	
MANUFACTURING		SIZE	DWG NO
ASSEMBLY		D	565575-CU
MATERIAL USED	-	SCALE	1/1
		SPN:	SIMILAR P/N
			SHEET 1 OF 2

NOTES:

1. BAG AND TAG 632D45 (12)

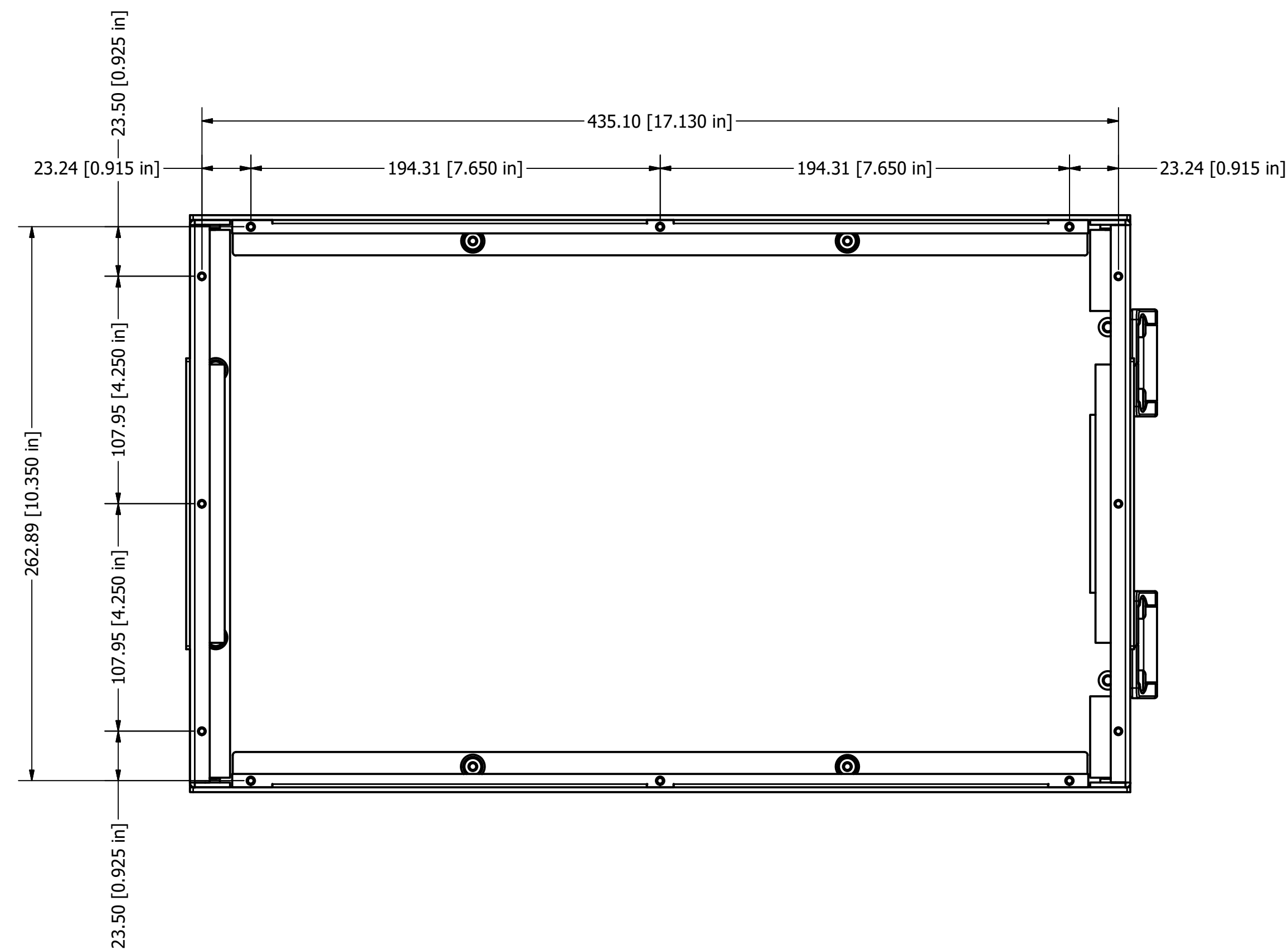
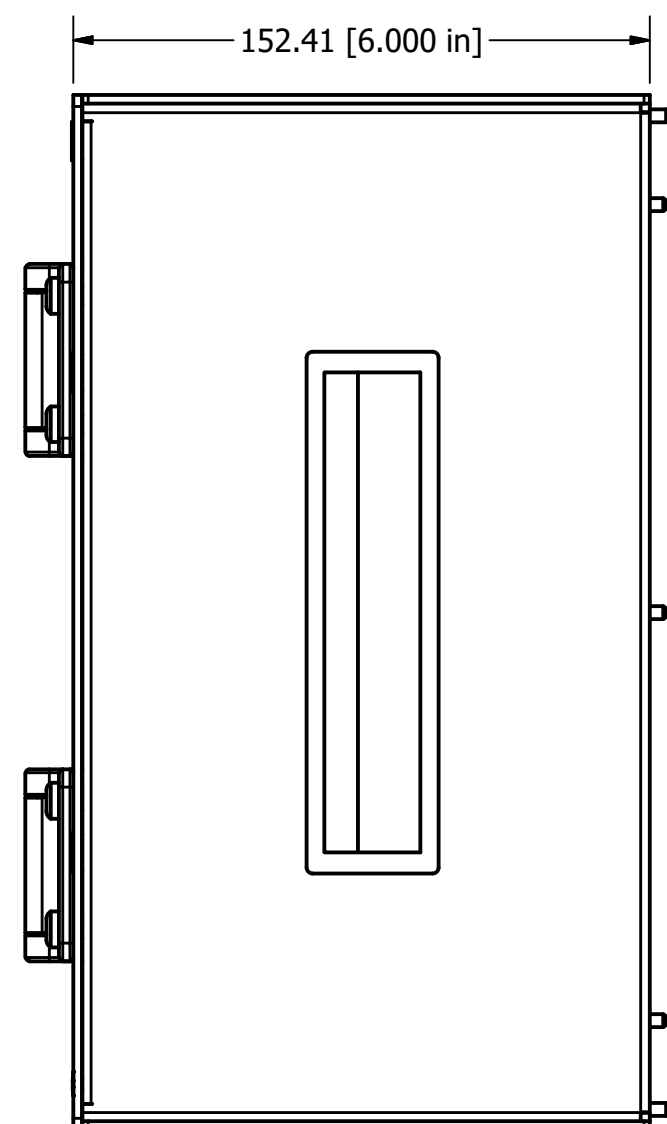
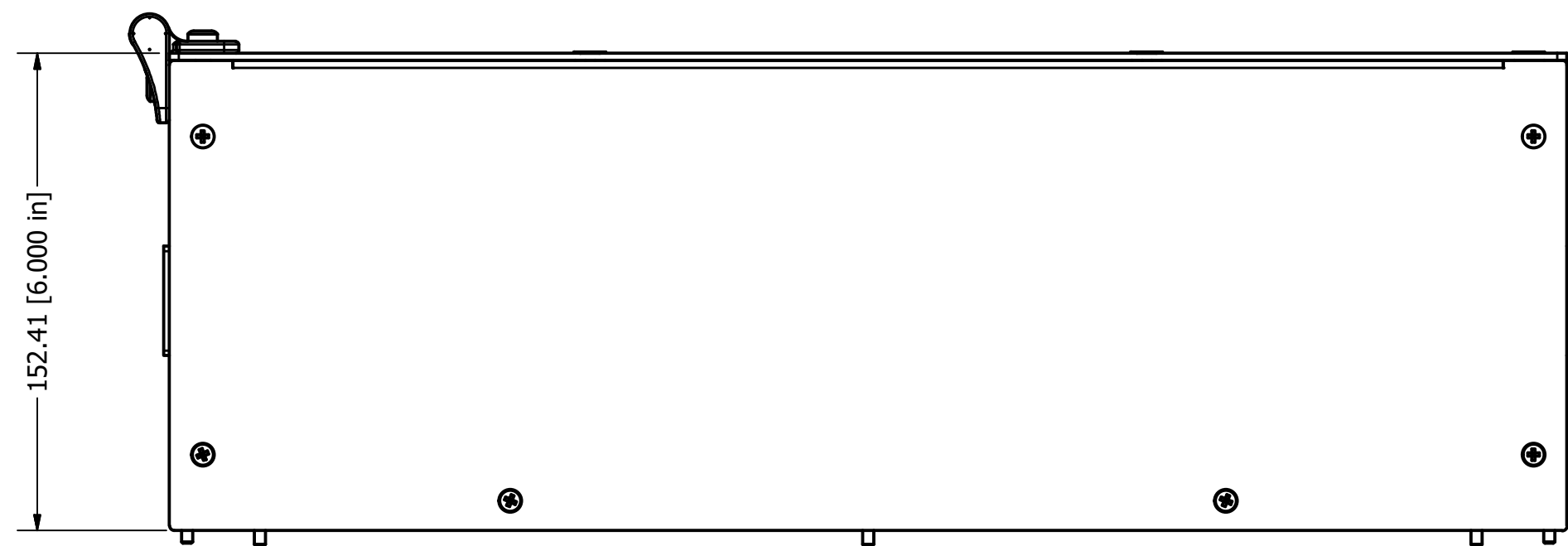
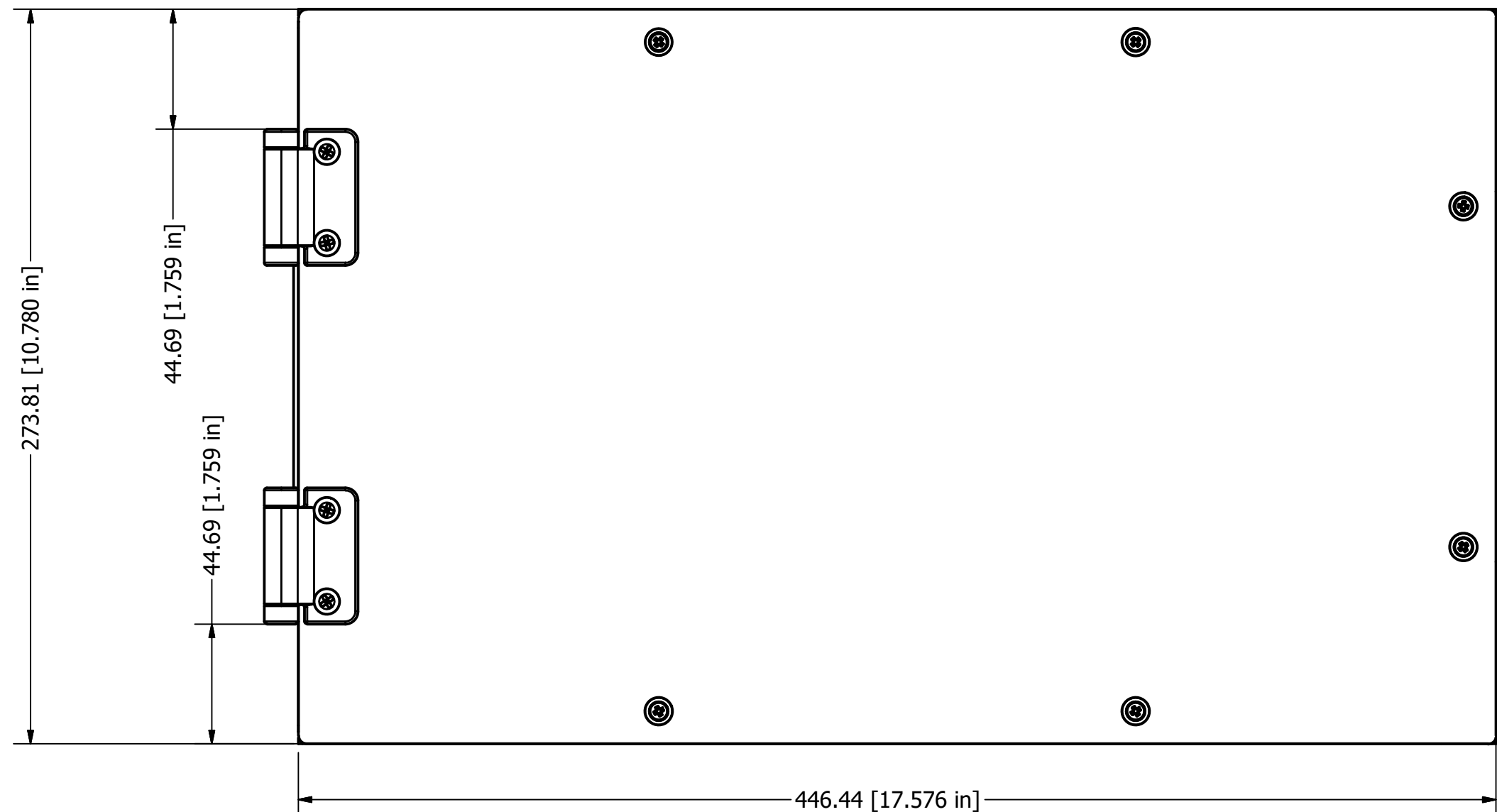
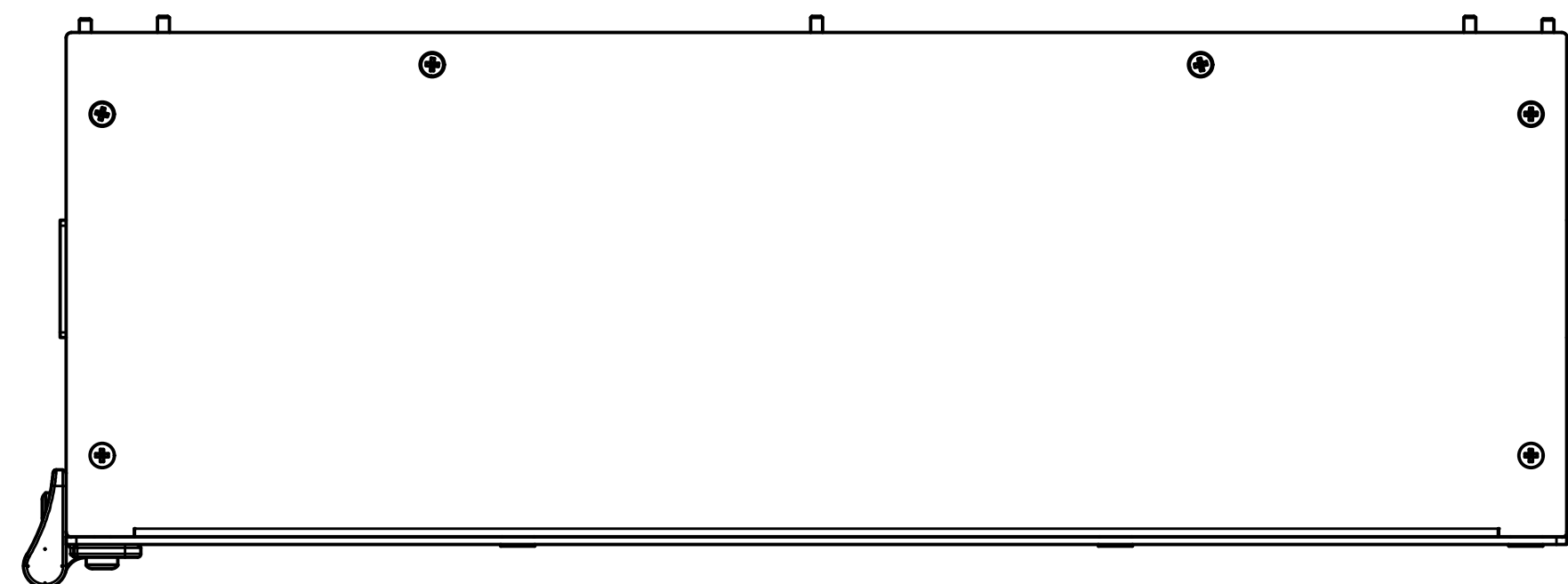

BALLOON LEGEND

PART NUMBER  
QTY

TOLERANCES (UNLESS OTHERWISE SPECIFIED)

SHEET METAL MACHINED  
 ANGLES ± 1° ANGLES ± 1°  
 .XX ± .03 .XX ± .01  
 .XXX ± .010 .XXX ± .005  
 .XXXX ± .0005

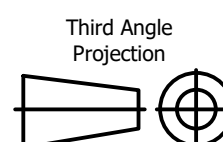

Third Angle  
Projection

REMOVE ALL BURRS AND BREAK SHARP EDGES.

DRAWN BY	DBCooper	20/08/2018
ENGINEERING		
OPERATIONS		
MANUFACTURING		
ASSEMBLY		
MATERIAL USED		

MAC PANEL COMPANY - HIGH POINT, NC	
TITLE	
21 SLOT SCOUT XT, ENCL 6" DP, LH	
SIZE	DWG NO
D	565575-CU
SCALE	1/1
SPN:	SIMILAR P/N
SHEET 2 OF 2	

A