

8 7 6 5 4 3 2 1

NOTES:

1.

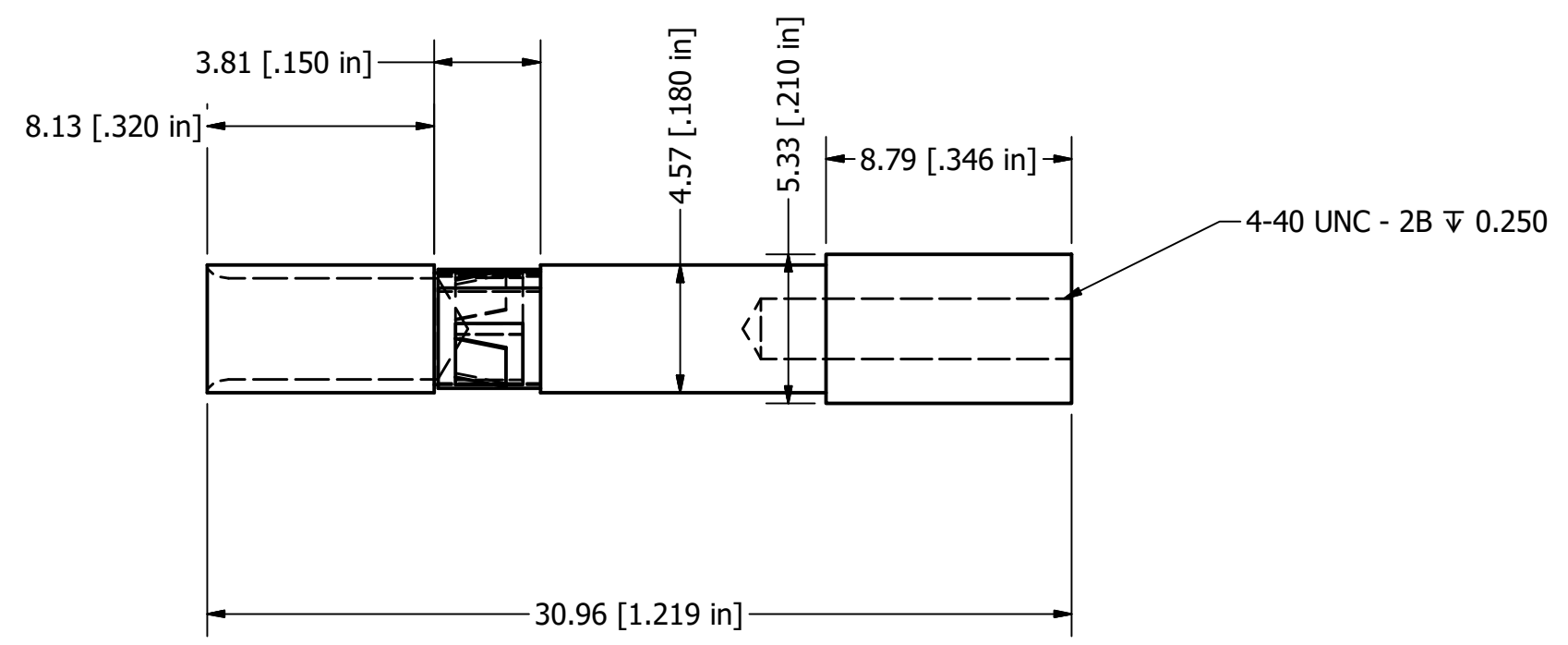
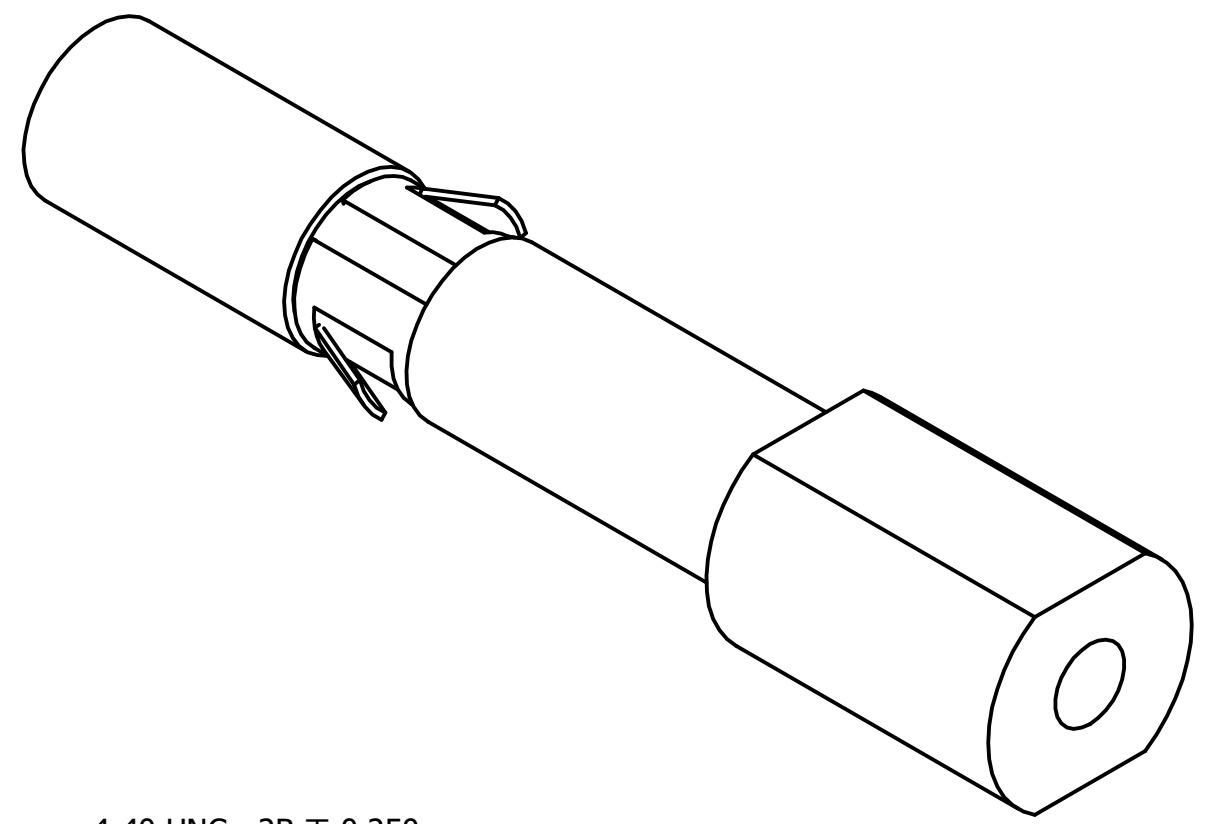

BALLOON LEGEND	
PART NUMBER	
QTY	

MAC PANEL PROPRIETARY
This document may contain confidential and proprietary information that is the property of MAC Panel Company that may not be disclosed to, or duplicated for others except as authorized by MAC Panel Company.

TOLERANCES (UNLESS OTHERWISE SPECIFIED)

<u>SHEET METAL</u>	<u>MACHINED</u>
ANGLES \pm 1'	ANGLES \pm 1'
.XX \pm .03	.XX \pm .01
.XXX \pm .010	.XXX \pm .005
	.XXXX \pm .0005

REMOVE ALL BURRS AND BREAK SHARP EDGES.

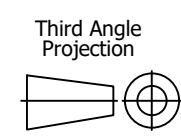

DRAWN BY	08/11/2018
DBCooper	
ENGINEERING	
OPERATIONS	
MANUFACTURING	
ASSEMBLY	
MATERIAL USED	

MAC PANEL COMPANY - HIGH POINT, NC			
TITLE			
GROUNDING LUG ASSEMBLY, PLUG, DISCRETE			
SIZE	CAGE CODE	DWG NO	REV
B	16654	562898-CU	A
SCALE	SPN:	SHEET 1 OF 1	

8 7 6 5 4 3 2 1