

NOTES:

1. BAG AND TAG P/NS M4F85 (8X), AND 632F85 (6X)

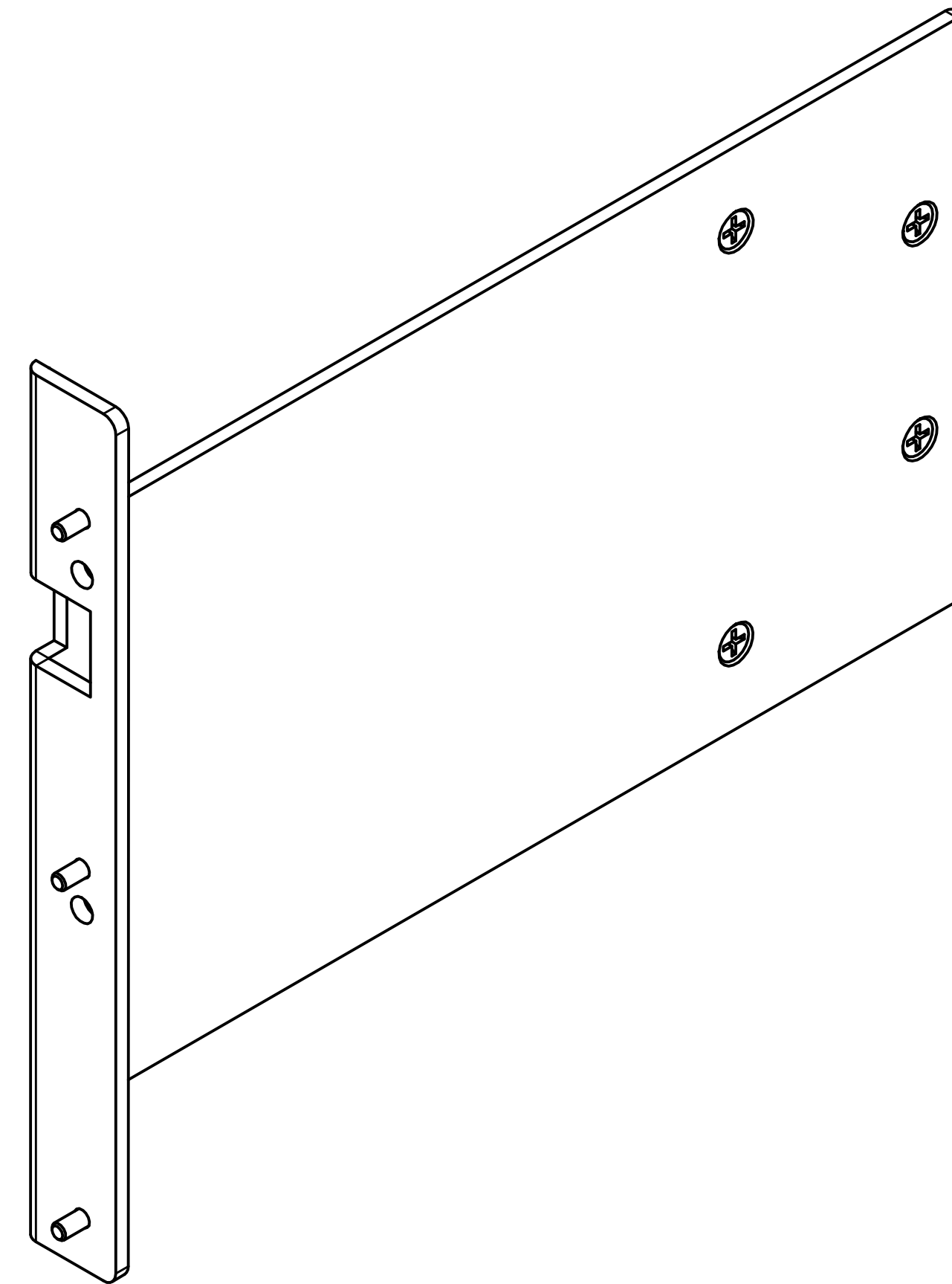
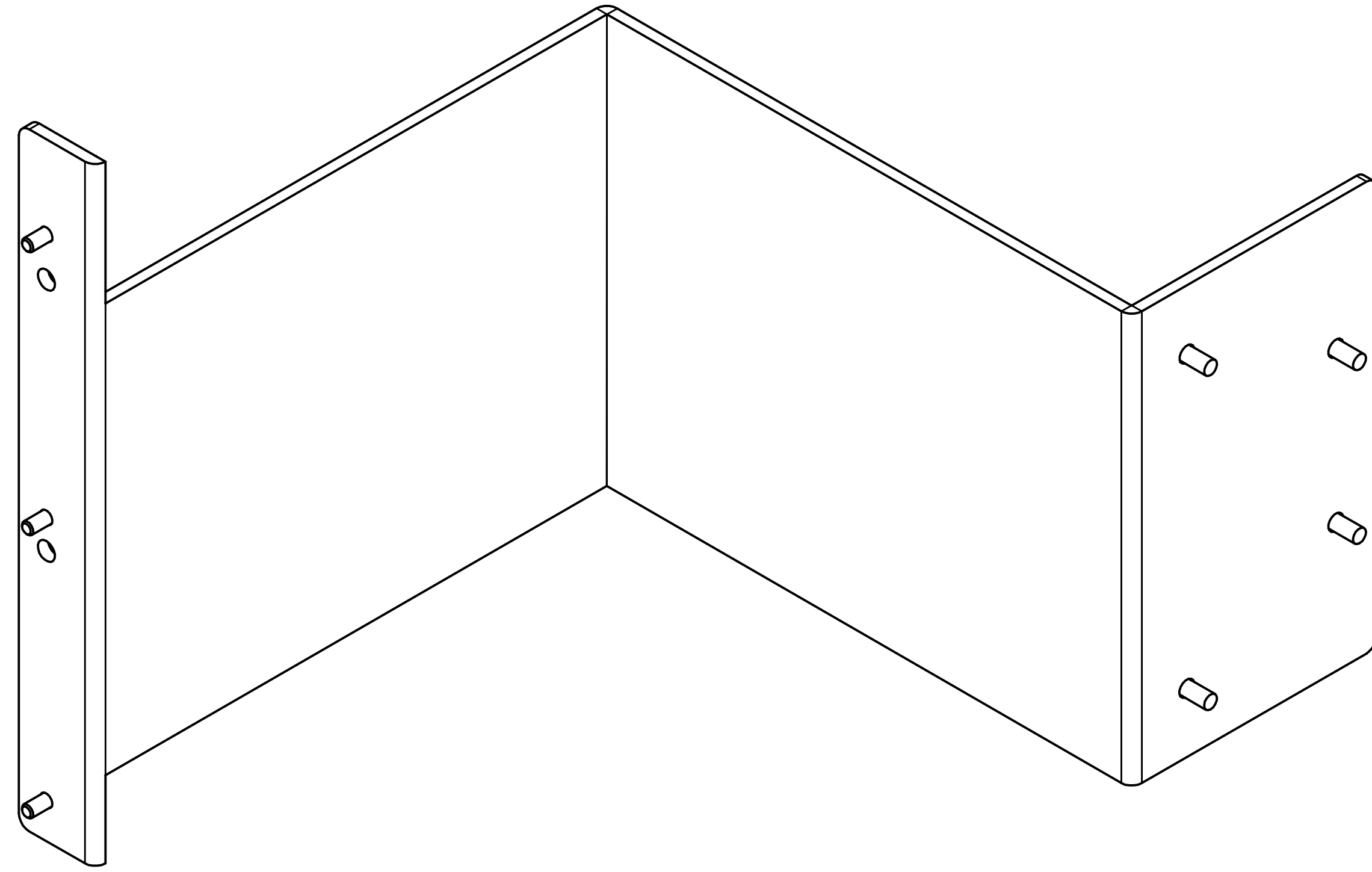

BALLOON LEGEND

PART NUMBER
QTY

MAC PANEL PROPRIETARY  
 This document may contain confidential and proprietary information that is the property of MAC Panel Company that may not be disclosed to, or duplicated for others except as authorized by MAC Panel Company.

TOLERANCES (UNLESS OTHERWISE SPECIFIED)  
 SHEET METAL MACHINED  
 ANGLES ± 1° ANGLES ± 1°  
 .XX ± .03 .XX ± .01  
 .XXX ± .010 .XXX ± .005  
 .XXXX ± .0005 .XXXX ± .0005

REMOVE ALL BURRS AND BREAK SHARP EDGES.

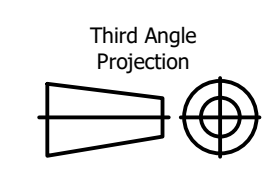

DRAWN BY  
 DCooper  
 ENGINEERING  
 OPERATIONS  
 MANUFACTURING  
 ASSEMBLY  
 MATERIAL USED

08/10/2018		MAC PANEL COMPANY - HIGH POINT, NC	
TITLE			
FLANGE KIT, 561820-PXI 1042/62/82, EXTENDED			
SIZE	CAGE CODE	DWG NO	REV
D	16654	561668X-CU	B
SCALE	SPN:	SHEET 1 OF 3	