

| REVISION HISTORY |                         |           |          |
|------------------|-------------------------|-----------|----------|
| REV              | DESCRIPTION             | DATE      | APPROVED |
| A                | RELEASED FOR PRODUCTION | 12/5/2007 | WKM      |

NOTES:

1. USE ASSEMBLY INSTRUCTIONS 5511198 FOR ATTACHING DAK TO PXI CARD.
2. MATING ITA MODULE P/N 561401.
3. SUPPLIED WITH MOUNTING HARDWARE.
4. SEE SHEET 3 FOR WIRE LIST.

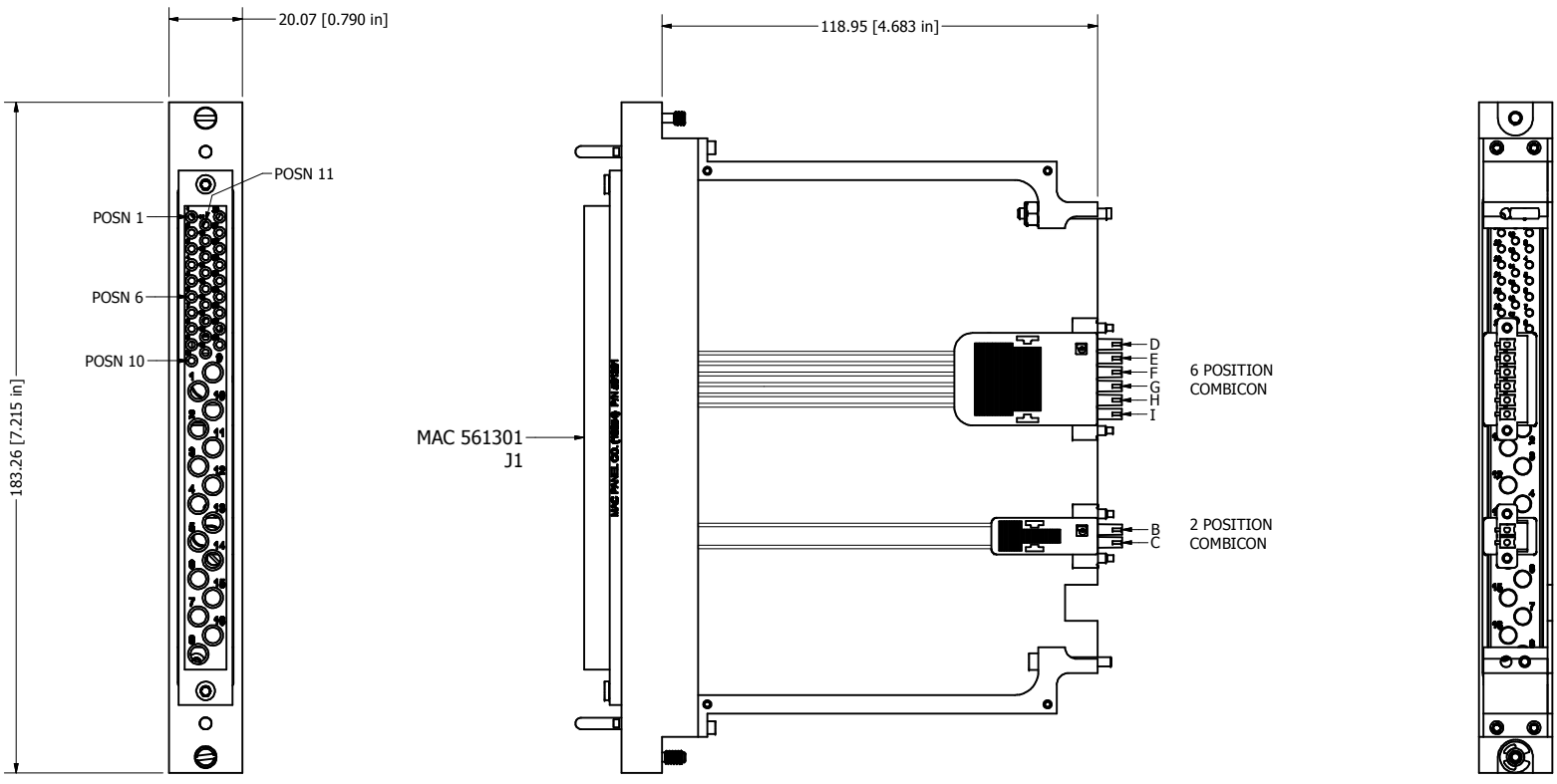

RIGHT SIDE PLATE REMOVED FOR CLARITY.

| BALLOON LEGEND |  |
|----------------|--|
| PART NUMBER    |  |
| QTY            |  |

|   |  |                                   |                   |   |
|---|--|-----------------------------------|-------------------|---|
| <p>MAC PANEL PROPRIETARY<br/>This document may contain confidential and proprietary information that is the property of MAC Panel Company that may not be disclosed to, or duplicated for others except as authorized by MAC Panel Company.</p> |  | <p>DRAWN BY<br/>WKM</p>           | <p>03/12/2007</p> | <p>MAC PANEL COMPANY - HIGH POINT, NC</p> |
| <p>TOLERANCES (UNLESS OTHERWISE SPECIFIED)</p>  |  | <p>ENGINEERING<br/>GAC</p>        | <p>03/12/2007</p> | <p>TITLE</p>                              |
| <p>SHEET METAL MACHINED</p>   |  | <p>OPERATIONS<br/>C.BOGGS</p>     | <p>03/12/2007</p> | <p>DAK ASSY, SCOUT, SGL, PXI-4110</p>     |
| <p>ANGLES ± 1° ANGLES ± 1°</p>  |  | <p>MANUFACTURING<br/>R.SPIVEY</p> | <p>03/12/2007</p> | <p>SIZE</p>                               |
| <p>Third Angle Projection</p>   |  | <p>ASSEMBLY</p>                   |                   | <p>DWG NO</p>                             |
| <p>REMOVE ALL BURRS AND BREAK SHARP EDGES.</p>  |  | <p>MATERIAL USED</p>              |                   | <p>561126-cu</p>                          |
|   |  | <p>SCALE</p>                      | <p>1/1</p>        | <p>SPN: 561143</p>                        |
|   |  |                                   |                   | <p>SHEET 1 OF 3</p>                       |

8 7 6 5 4 3 2 1

NOTES:

1. USE ASSEMBLY INSTRUCTIONS 5511198 FOR ATTACHING DAK TO PXI CARD.
2. MATING ITA MODULE P/N 561401.
3. SUPPLIED WITH MOUNTING HARDWARE.
4. SEE SHEET 3 FOR WIRE LIST.

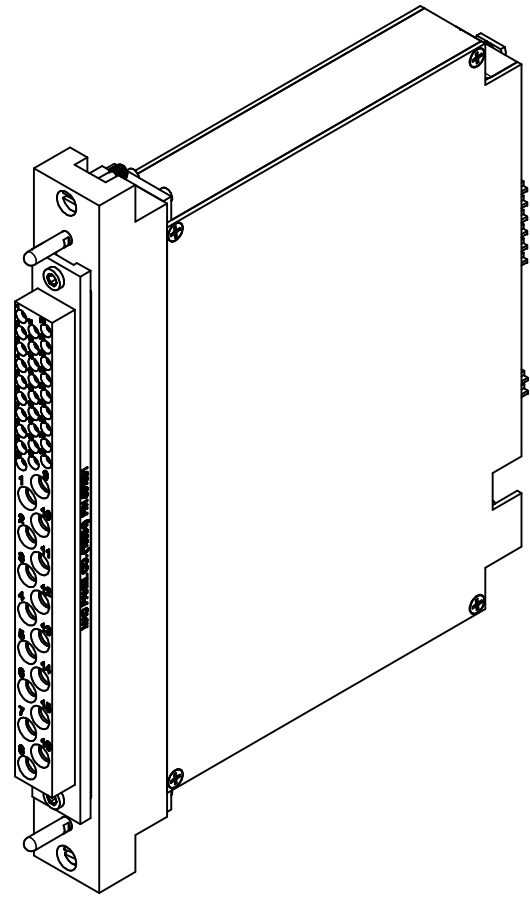

D  
C  
B  
A

D  
C  
B  
A

**BALLOON LEGEND**  
PART NUMBER  
QTY

|   |  |  |   |
|---|--|--|---|
| <p>MAC PANEL PROPRIETARY<br/>This document may contain confidential and proprietary information that is the property of MAC Panel Company that may not be disclosed to, or duplicated for others except as authorized by MAC Panel Company.</p> |  | <p>DRAWN BY<br/>WKM<br/>03/12/2007</p>           | <p>MAC PANEL COMPANY - HIGH POINT, NC</p> |
| <p>TOLERANCES (UNLESS OTHERWISE SPECIFIED)<br/>SHEET METAL MACHINED</p>   |  | <p>ENGINEERING<br/>GAC<br/>03/12/2007</p>        | <p>TITLE</p>                              |
| <p>ANGLES ± 1° ANGLES ± 1°<br/>Third Angle Projection</p>   |  | <p>OPERATIONS<br/>C.BOGGS<br/>03/12/2007</p>     | <p>DAK ASSY, SCOUT, SGL, PXI-4110</p>     |
| <p>REMOVE ALL BURRS AND BREAK SHARP EDGES.</p>  |  | <p>MANUFACTURING<br/>R.SPIVEY<br/>03/12/2007</p> | <p>ASSEMBLY</p>                           |
| <p>MATERIAL USED</p>  |  | <p>SIZE<br/>C</p>                                | <p>DWG NO<br/>561126-cu</p>               |
| <p>SCALE 1/1</p>  |  | <p>SPN: 561143</p>                               | <p>SHEET 2 OF 3</p>                       |

8 7 6 5 4 3 2 1

NOTES:

1. USE ASSEMBLY INSTRUCTIONS 5511198 FOR ATTACHING DAK TO PXI CARD.
2. MATING ITA MODULE P/N 561401.
3. SUPPLIED WITH MOUNTING HARDWARE.
4. SEE SHEET 3 FOR WIRE LIST.

| 561126WL         |                     |                  |                     |
|------------------|---------------------|------------------|---------------------|
| MAC 561301<br>J1 | 6 Position Combicon | MAC 561301<br>J1 | 2 Position Combicon |
| 1                | D                   | 10               | B                   |
| 2                | E                   | 11               | C                   |
| 3                | F                   |                  |                     |
| 4                | G                   |                  |                     |
| 5                | H                   |                  |                     |
| 6                | I                   |                  |                     |

D  
C  
B  
A

D  
C  
B  
A

|   |   |   |  |   |
|---|---|---|--|---|
| <b>BALLOON LEGEND</b><br><div style="border: 1px solid black; border-radius: 50%; width: 40px; height: 20px; margin: 5px auto; display: flex; align-items: center; justify-content: center;">                 PART NUMBER<br/>                 QTY             </div> | MAC PANEL PROPRIETARY<br>This document may contain confidential and proprietary information that is the property of MAC Panel Company that may not be disclosed to, or duplicated for others except as authorized by MAC Panel Company.                     | DRAWN BY<br>WKM<br>ENGINEERING<br>GAC<br>OPERATIONS<br>C.BOGGS<br>MANUFACTURING<br>R.SPIVEY<br>ASSEMBLY | 03/12/2007<br>03/12/2007<br>03/12/2007<br>03/12/2007 | MAC PANEL COMPANY - HIGH POINT, NC<br>TITLE<br>DAK ASSY, SCOUT, SGL, PXI-4110 |
|   | TOLERANCES (UNLESS OTHERWISE SPECIFIED)<br>SHEET METAL    MACHINED<br>ANGLES ± 1°    ANGLES ± 1°<br>.XX ± .03    .XX ± .01    ± .20 mm<br>.XXX ± .010    .XXX ± .005    ± .100 mm<br>.XXXX ± .0005    ± .0100 mm<br>REMOVE ALL BURRS AND BREAK SHARP EDGES. | Third Angle Projection<br>  | MATERIAL USED<br>-                                   | SIZE<br>C<br>DWG NO<br>561126-cu  |