

REVISION HISTORY			
REV	DESCRIPTION	DATE	APPROVED
A	RELEASED FOR PRODUCTION	7/24/2007	WKM

NOTES:

1. USE INSTRUCTION SHEET IN91100 FOR ATTACHING DAK TO PXI CARD
2. RECEIVER / ITA MODULE TO BE KEYED ON RIGHT SIDE
3. MATING ITA MODULE P/N 561403.
4. SUPPLIED WITH MOUNTING HARDWARE.
5. SEE SHEET 3 FOR WIRE LIST.

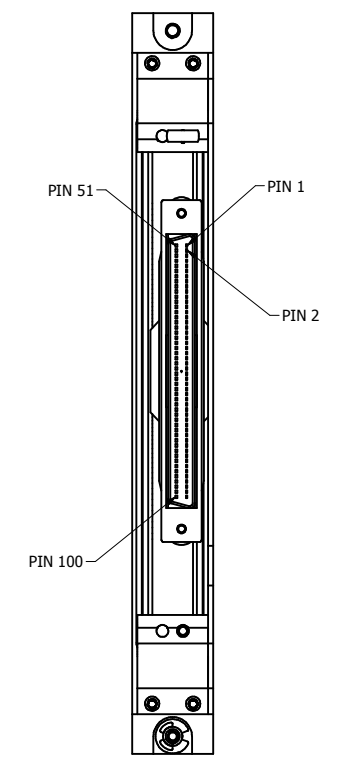
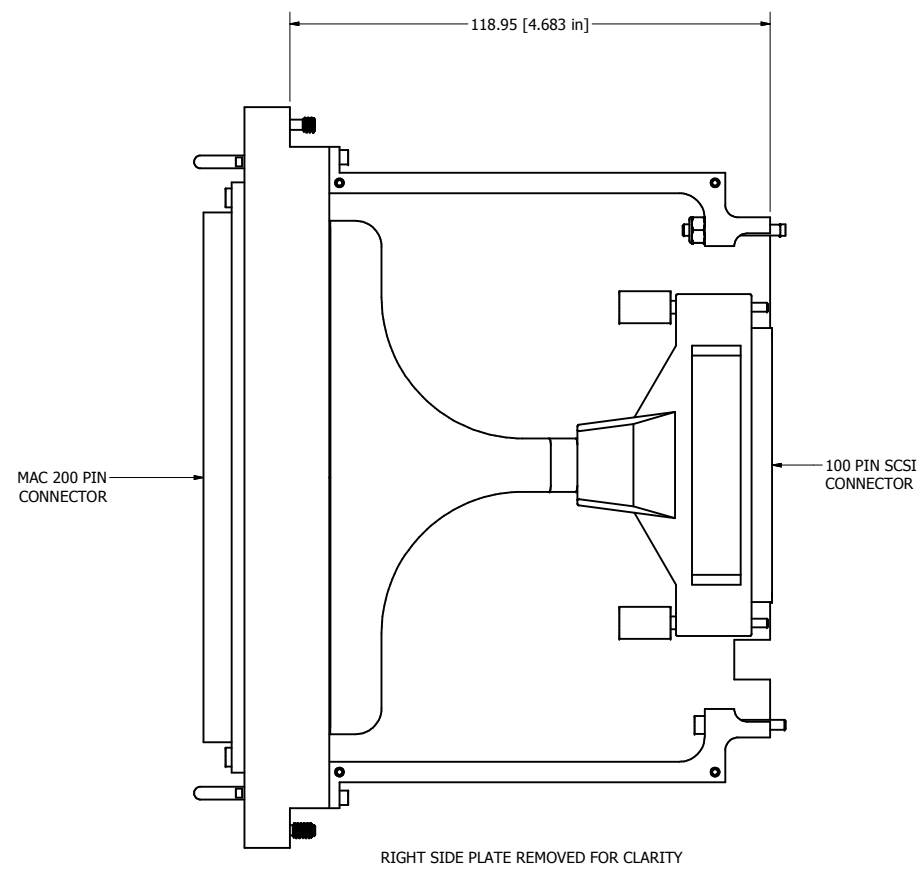
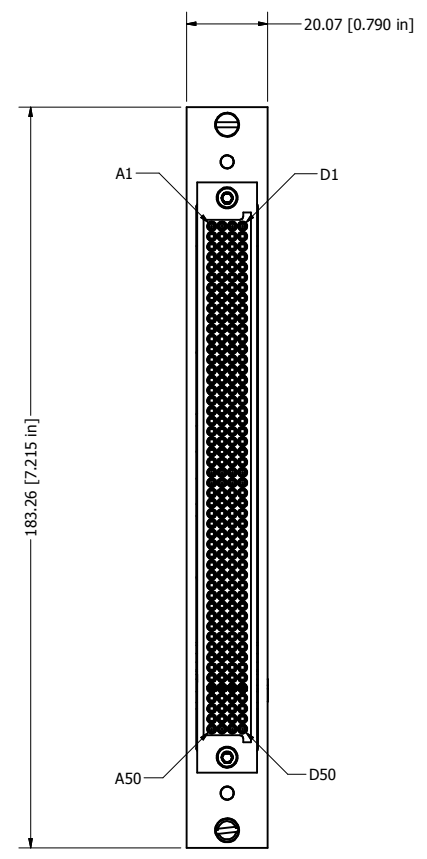

BALLOON LEGEND	
PART NUMBER	QTY

MAC PANEL PROPRIETARY  
 This document may contain confidential and proprietary information that is the property of MAC Panel Company that may not be disclosed to, or duplicated for others except as authorized by MAC Panel Company.

TOLERANCES (UNLESS OTHERWISE SPECIFIED)

SHEET METAL	MACHINED
ANGLES ± 1'	ANGLES ± 1'
.XX ± .03	.XX ± .01
.XXX ± .010	.XXX ± .005
	.XXX ± .0005

REMOVE ALL BURRS AND BREAK SHARP EDGES.

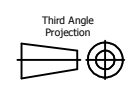

DRAWN BY WKM	24/07/2007	MAC PANEL COMPANY - HIGH POINT, NC
ENGINEERING GAC	24/07/2007	
OPERATIONS C.BOGGS	24/07/2007	TITLE
MANUFACTURING R.SPIVEY	24/07/2007	DAK ASSY, SCOUT, 100 PIN INVERTED SCSI
ASSEMBLY		
MATERIAL USED		SIZE C
		DWG NO 561117-cu
		SCALE 1/1
		SPN: SIMILAR P/N
		SHEET 1 OF 3

NOTES:

1. USE INSTRUCTION SHEET IN91100 FOR ATTACHING DAK TO PXI CARD
2. RECEIVER / ITA MODULE TO BE KEYED ON RIGHT SIDE
3. MATING ITA MODULE P/N 561403.
4. SUPPLIED WITH MOUNTING HARDWARE.
5. SEE SHEET 3 FOR WIRE LIST.

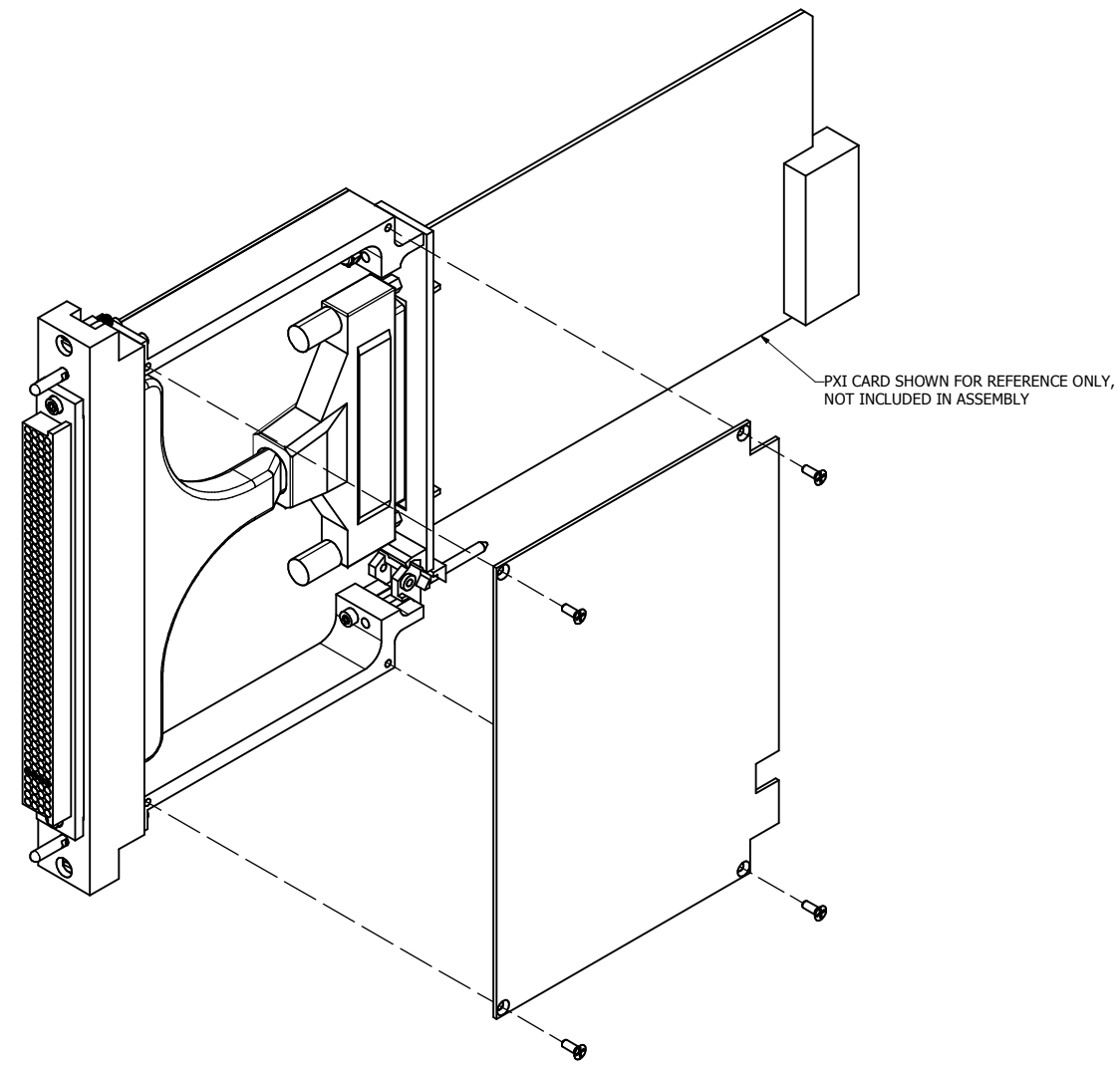

BALLOON LEGEND	
PART NUMBER	QTY

MAC PANEL PROPRIETARY  
 This document may contain confidential and proprietary information that is the property of MAC Panel Company that may not be disclosed to, or duplicated for others except as authorized by MAC Panel Company.

TOLERANCES (UNLESS OTHERWISE SPECIFIED)

SHEET METAL	MACHINED
ANGLES ± 1'	ANGLES ± 1'
.XX ± .03	.XX ± .01
.XXX ± .010	.XXX ± .005
	.XXX ± .0005

REMOVE ALL BURRS AND BREAK SHARP EDGES.

Third Angle Projection

DRAWN BY	24/07/2007
WKM	
ENGINEERING	
GAC	24/07/2007
OPERATIONS	
C.BOGGS	24/07/2007
MANUFACTURING	
R.SPIVEY	24/07/2007
ASSEMBLY	
MATERIAL USED	
-	

MAC PANEL COMPANY - HIGH POINT, NC	
TITLE	
DAK ASSY, SCOUT, 100 PIN INVERTED SCSI	
SIZE	DWG NO
C	561117-cu
SCALE	SPN: SIMILAR P/N
1/1	SHEET 2 OF 3

NOTES:

1. USE INSTRUCTION SHEET IN91100 FOR ATTACHING DAK TO PXI CARD
2. RECEIVER / ITA MODULE TO BE KEYED ON RIGHT SIDE
3. MATING ITA MODULE P/N 561403.
4. SUPPLIED WITH MOUNTING HARDWARE.
5. SEE SHEET 3 FOR WIRE LIST.

561117WL							
MAC 200 PIN CONNECTOR	100 PIN SCSI CONNECTOR	MAC 200 PIN CONNECTOR	100 PIN SCSI CONNECTOR	MAC 200 PIN CONNECTOR	100 PIN SCSI CONNECTOR	MAC 200 PIN CONNECTOR	100 PIN SCSI CONNECTOR
D50	52	C50	51	B50	2	A50	1
D49	54	C49	53	B49	4	A49	3
D48	56	C48	55	B48	6	A48	5
D47	58	C47	57	B47	8	A47	7
D46	60	C46	59	B46	10	A46	9
D45	62	C45	61	B45	12	A45	11
D44	64	C44	63	B44	14	A44	13
D43	66	C43	65	B43	16	A43	15
D42	68	C42	67	B42	18	A42	17
D41	70	C41	69	B41	20	A41	19
D40	72	C40	71	B40	22	A40	21
D39	74	C39	73	B39	24	A39	23
D38	76	C38	75	B38	26	A38	25
D37	78	C37	77	B37	28	A37	27
D36	80	C36	79	B36	30	A36	29
D35	82	C35	81	B35	32	A35	31
D34	84	C34	83	B34	34	A34	33
D33	86	C33	85	B33	36	A33	35
D32	88	C32	87	B32	38	A32	37
D31	90	C31	89	B31	40	A31	39
D30	92	C30	91	B30	42	A30	41
D29	94	C29	93	B29	44	A29	43
D28	96	C28	95	B28	46	A28	45
D27	98	C27	97	B27	48	A27	47
D26	100	C26	99	B26	50	A26	49

**BALLOON LEGEND**

PART NUMBER
QTY

**MAC PANEL PROPRIETARY**  
This document may contain confidential and proprietary information that is the property of MAC Panel Company that may not be disclosed to, or duplicated for others except as authorized by MAC Panel Company.

**TOLERANCES (UNLESS OTHERWISE SPECIFIED)**

<u>SHEET METAL</u>	<u>MACHINED</u>
ANGLES ± 1'	ANGLES ± 1'
.XX ± .03	.XX ± .01
.XXX ± .010	.XXX ± .005
	.XXX ± .0005

Third Angle Projection



REMOVE ALL BURRS AND BREAK SHARP EDGES.

DRAWN BY	WKM	24/07/2007
ENGINEERING	GAC	24/07/2007
OPERATIONS	C.BOGGS	24/07/2007
MANUFACTURING	R.SPIVEY	24/07/2007
ASSEMBLY		
MATERIAL USED	-	

MAC PANEL COMPANY - HIGH POINT, NC

**TITLE**

DAK ASSY, SCOUT, 100 PIN INVERTED SCSI

SIZE	C	DWG NO	561117-cu
SCALE	1/1	SPN:	SIMILAR P/N

SHEET 3 OF 3