

NOTES:

1. USE INSTRUCTION SHEET IN9110 FOR ATTACHING DAK TO PXI CARD.
2. MATING ITA MODULE P/N 561402.
3. SUPPLIED WITH MOUNTING HARDWARE.
4. SEE SHEET 3 FOR WIRE LIST.

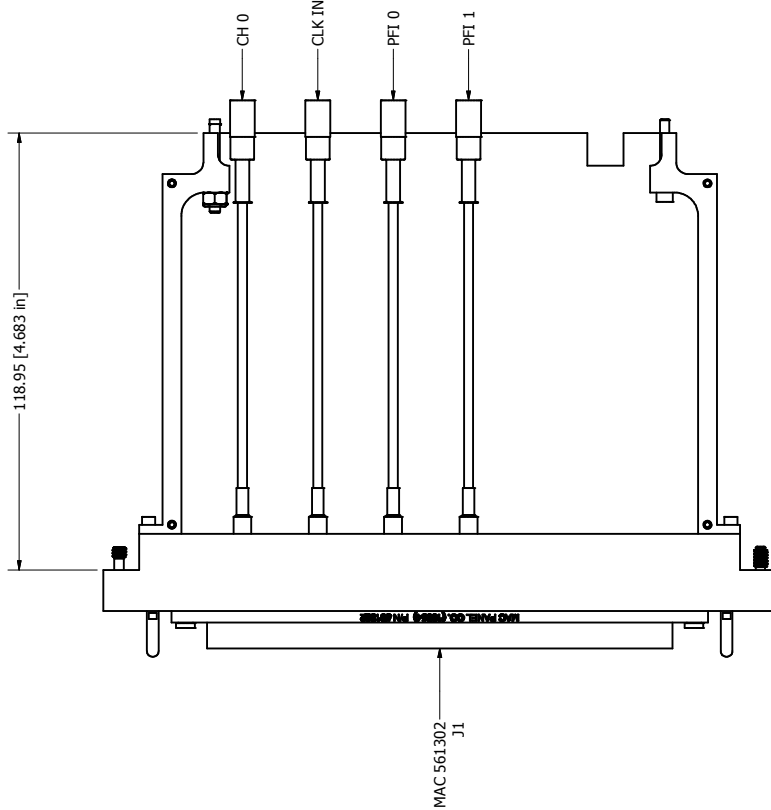

RIGHT SIDE PLATE REMOVED FOR CLARITY.

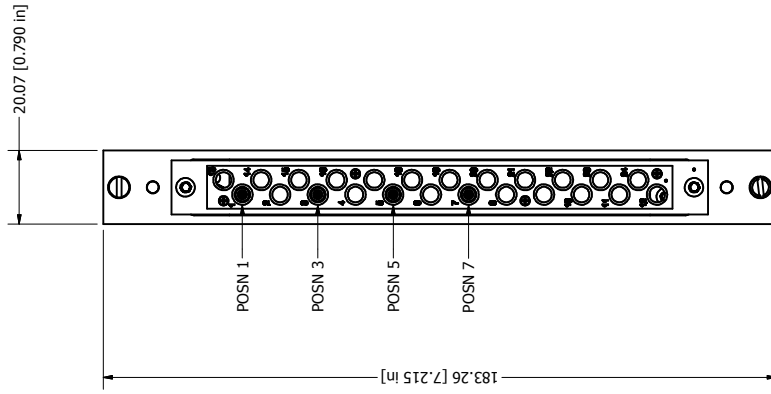
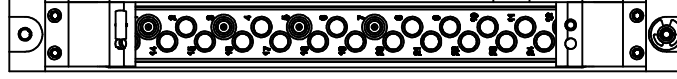

REV	DESCRIPTION	DATE	APPROVED
A	RELEASE FOR PRODUCTION	4/18/2007	WKM
B	ECN #2057 (REPLACED 603002 WITH 561302)	5/31/2007	WKM

DRAWN BY WKM ENGINEERING M4		13/04/2007	MAC PANEL COMPANY - HIGH POINT, NC	
OPERATIONS C. BOGGS		18/04/2007	TITLE	
MANUFACTURING R. SPIVEY		18/04/2007	DAK ASSY, SCOUT, PXI-5412	
ASSEMBLY			SIZE C	
MATERIAL USED -			DWG NO 561076-CU	
			SCALE 1/1 SPR: SIMILAR P/N	
			SHEET 1 OF 3	

<p>MAC PANEL PROPRIETARY</p> <p>This document may contain confidential and proprietary information that is the property of MAC Panel Company that may not be disclosed to, or duplicated for others except as authorized by MAC Panel Company.</p>		<p>Third Angle Projection</p>
<p>TOLERANCES (UNLESS OTHERWISE SPECIFIED)</p> <p>SHEET METAL MACHINED</p> <p>ANGLES ± 1° ANGLES ± 1°</p> <p>± .03 ± .01</p> <p>.XX .XX</p> <p>.XXX ± .010 .XXXX ± .0005</p>	<p>REMOVE ALL BURRS AND BREAK SHARP EDGES.</p>	

BALLOON LEGEND	
PART NUMBER	QTY

NOTES:

1. USE INSTRUCTION SHEET IN9110 FOR ATTACHING DAK TO PXI CARD.
2. MATING ITA MODULE P/N 561402.
3. SUPPLIED WITH MOUNTING HARDWARE.
4. SEE SHEET 3 FOR WIRE LIST.

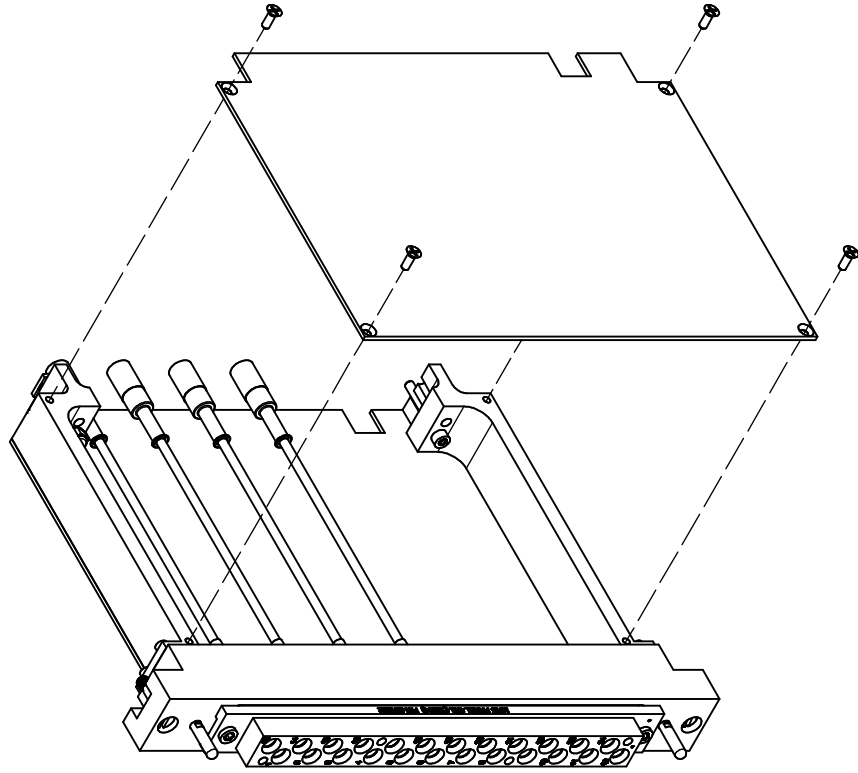

BALLOON LEGEND

PART NUMBER	QTY

MAC PANEL PROPRIETARY
 This document may contain confidential and proprietary information that is the property of MAC Panel Company that may not be disclosed to, or duplicated for others except as authorized by MAC Panel Company.

TOLEANCES (UNLESS OTHERWISE SPECIFIED)
 SHEET METAL MACHINED
 ANGLES ± 1°
 .XX ± .01
 .XXX ± .010
 .XXXX ± .005
 Third Angle Projection
 REMOVE ALL BURRS AND BREAK SHARP EDGES.

DRAWN BY	13/04/2007
WIKM	
ENGINEERING	18/04/2007
M4	
OPERATIONS	18/04/2007
C. BOGGS	
MANUFACTURING	18/04/2007
R. SPIVEY	
ASSEMBLY	
MATERIAL USED	
-	

MAC PANEL COMPANY - HIGH POINT, NC	
TITLE	
DAK ASSY, SCOUT, PXI-5412	
SIZE	DWG NO
C	561076-CU
SCALE	1/1
	SPR: SIMILAR P/N
	SHEET 2 OF 3

NOTES:

1. USE INSTRUCTION SHEET IN9110 FOR ATTACHING DAK TO PXI CARD.
2. MATING ITA MODULE P/N 561402.
3. SUPPLIED WITH MOUNTING HARDWARE.
4. SEE SHEET 3 FOR WIRE LIST.

561076WL	
MAC 561302 J1	M1313403001 SMB
1	CH0
3	CLK IN
5	PFI 0
7	PFI 1

BALLOON LEGEND



MAC PANEL PROPRIETARY
This document may contain confidential and proprietary information that is the property of MAC Panel Company that may not be disclosed to, or duplicated for others except as authorized by MAC Panel Company.

TOOLERANCES (UNLESS OTHERWISE SPECIFIED)
SHEET METAL MACHINED
ANGLES ± 1°
± .02
.XX ± .05
.XXX ± .010
ANGLES ± 1°
± .01
.XX ± .05
.XXX ± .005
Third Angle Projection



REMOVE ALL BURRS AND BREAK SHARP EDGES.

DRAWN BY WKM ENGINEERING M4	13/04/2007	MAC PANEL COMPANY - HIGH POINT, NC
OPERATIONS C. BOGGS	18/04/2007	TITLE
MANUFACTURING R. SPIVEY	18/04/2007	DAK ASSY, SCOUT, PXI-5412
ASSEMBLY		SIZE C
MATERIAL USED -		DWG NO 561076-CU
		SCALE 1/1
		SPR: SIMILAR P/N
		SHEET 3 OF 3