

1 2 3 4 5 6 7 8

NOTES:

1. USE INSTRUCTION SHEET IN91100 FOR ATTACHING DAK TO PXI CARD
2. MATING ITA MODULE P/N 561411.
3. SUPPLIED WITH MOUNTING HARDWARE.
4. SEE SHEET 3 FOR WIRE LIST.

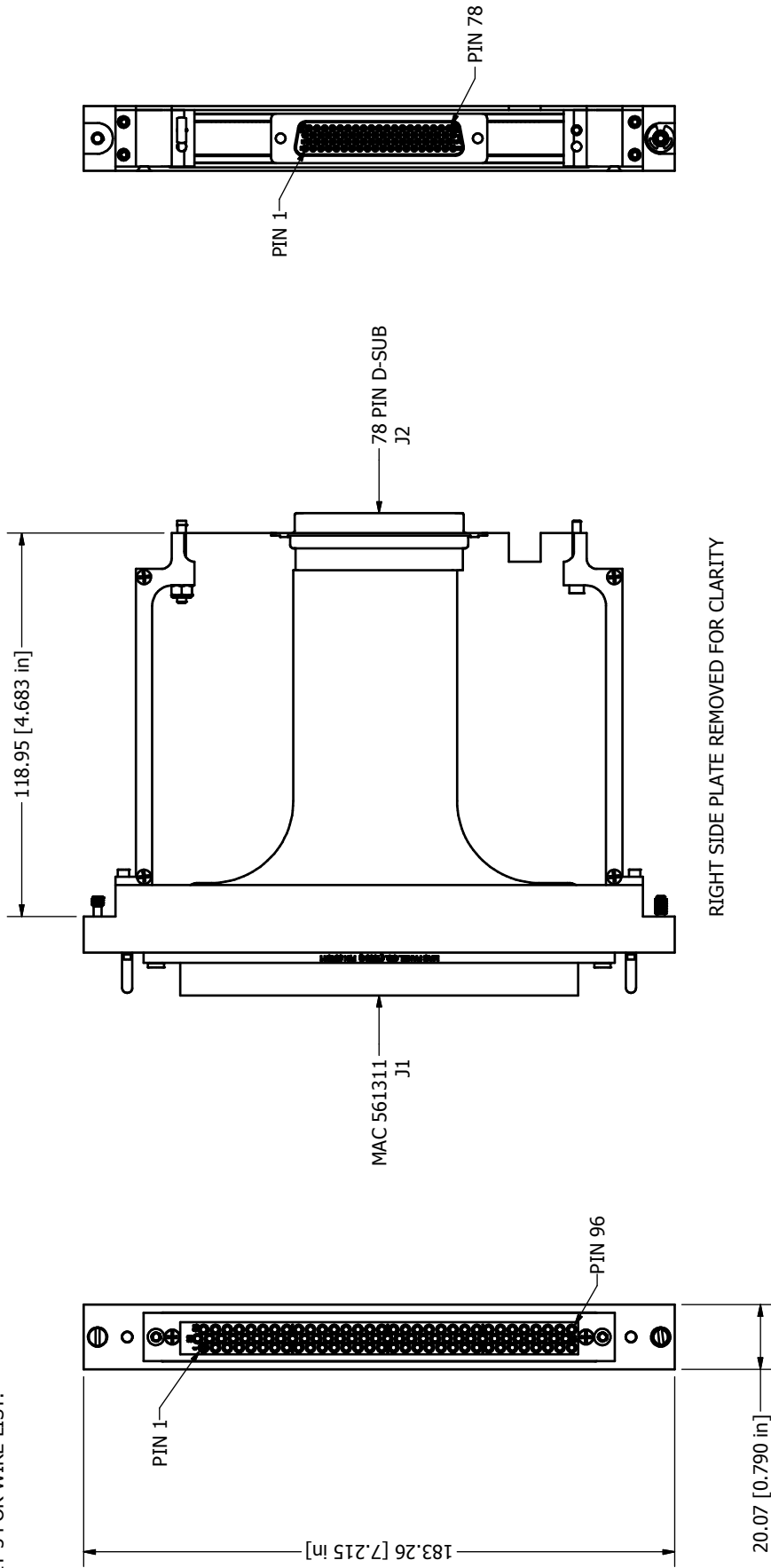

RIGHT SIDE PLATE REMOVED FOR CLARITY

REV	DESCRIPTION	DATE	APPROVED
A	RELEASED FOR PRODUCTION	2/29/2008	AO

DRAWN BY AO		13/02/2008	MAC PANEL COMPANY - HIGH POINT, NC	
ENGINEERING GAC			TITLE	
OPERATIONS C. BOGGS		29/02/2008	DAK ASSY, PICK, CABLE, 78P D-SUB FEMALE	
MANUFACTURING R. SPIVEY		29/02/2008	SIZE B	
ASSEMBLY			DWG NO 561073-CU	
MATERIAL USED			SCALE .75/1	
			SPN: SIMILAR P/N	
			SHEET 1 OF 3	

MAC PANEL PROPRIETARY
This document may contain confidential and proprietary information that is the property of MAC Panel Company that may not be disclosed to, or duplicated for others except as authorized by MAC Panel Company.

TOLERANCES (UNLESS OTHERWISE SPECIFIED)
SHEET METAL MACHINED
Third Angle Projection

ANGLES ± 1° ANGLES ± 1°
XX ± .03 XX ± .01
.XXX ± .005 .XXX ± .005
.XXX ± .010 .XXX ± .005
REMOVE ALL BURRS AND BREAK SHARP EDGES.

BALLOON LEGEND
PART NUMBER
QTY

D C B A

1 2 3 4 5 6 7 8

NOTES:

1. USE INSTRUCTION SHEET IN91100 FOR ATTACHING DAK TO PXI CARD
2. MATING ITA MODULE P/N 561411.
3. SUPPLIED WITH MOUNTING HARDWARE.
4. SEE SHEET 3 FOR WIRE LIST.

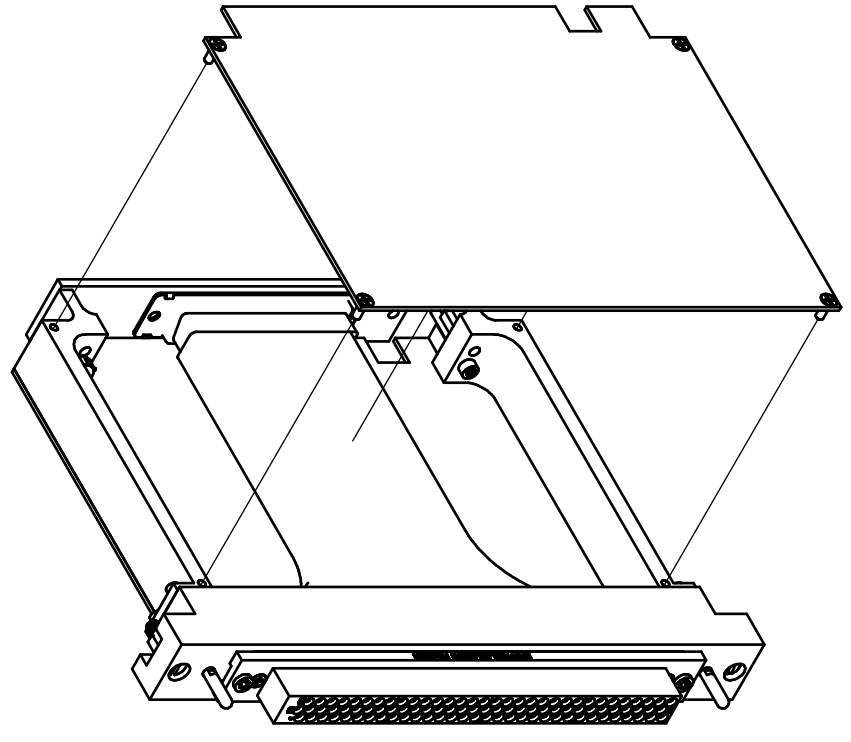

D C B A

D C B A

DRAWN BY AO		13/02/2008	MAC PANEL COMPANY - HIGH POINT, NC	
ENGINEERING GAC			TITLE	
OPERATIONS		29/02/2008	DAK ASSY,PICK,CABLE,78P D-SUB FEMALE	
C.BOGGS MANUFACTURING		29/02/2008	SIZE B	DWG NO 561073-CU
R.SPIVEY ASSEMBLY			SCALE .75/1	SPN- SIMILAR P/N
MATERIAL USED				

MAC PANEL PROPRIETARY
This document may contain confidential and proprietary information that is the property of MAC Panel Company that may not be disclosed to, or duplicated for others except as authorized by MAC Panel Company.

TOLERANCES (UNLESS OTHERWISE SPECIFIED)
SHEET METAL MACHINED
ANGLES ± 1° ANGLES ± 1°
XX ±.03 XX ±.01
.XXX ±.010 .XXX ±.005
.XXX ±.010 .XXX ±.005
REMOVE ALL BURRS AND BREAK SHARP EDGES.

BALLOON LEGEND

PART NUMBER	QTY

1 2 3 4 5 6 7 8

NOTES:

1. USE INSTRUCTION SHEET IN91100 FOR ATTACHING DAK TO PXI CARD
2. MATING ITA MODULE P/N 561411.
3. SUPPLIED WITH MOUNTING HARDWARE.
4. SEE SHEET 3 FOR WIRE LIST.

561073WL			
MAC 561311 J1	M7485691 D-SUB J2	MAC 561311 J1	M7485691 D-SUB J2
1	1	38	38
2	2	39	39
3	3	40	40
4	4	41	41
5	5	42	42
6	6	43	43
7	7	44	44
8	8	45	45
9	9	46	46
10	10	47	47
11	11	48	48
12	12	49	49
13	13	50	50
14	14	51	51
15	15	52	52
16	16	53	53
17	17	54	54
18	18	55	55
19	19	56	56
20	20	57	57
21	21	58	58
22	22	59	59
23	23	60	60
24	24	61	61
25	25	62	62
26	26	63	63
27	27	64	64
28	28	65	65
29	29	66	66
30	30	67	67
31	31	68	68
32	32	69	69
33	33	70	70
34	34	71	71
35	35	72	72
36	36	73	73
37	37	74	74
		75	75
		76	76
		77	77
		78	78

<p>MAC PANEL PROPRIETARY This document may contain confidential and proprietary information that is the property of MAC Panel Company that may not be disclosed to, or duplicated for others except as authorized by MAC Panel Company.</p>		<p>DRAWN BY AO ENGINEERING GAC</p>	<p>13/02/2008</p>	<p>MAC PANEL COMPANY - HIGH POINT, NC</p>
<p>TOLERANCES (UNLESS OTHERWISE SPECIFIED) SHEET METAL MACHINED ANGLES ± 1° ANGLES ± 1° XX ±.03 .XX ±.01 .XXX ±.010 .XXX ±.005 .XXXX ±.005</p>		<p>OPERATIONS C.BOGGS MANUFACTURING R.SPIVEY ASSEMBLY</p>	<p>29/02/2008 29/02/2008</p>	<p>TITLE DAK ASSY,PICK,CABLE,78P D-SUB FEMALE</p>
<p>BALLOON LEGEND PART NUMBER QTY</p>		<p>MATERIAL USED -</p>		<p>SIZE B</p>
<p>REMOVE ALL BURRS AND BREAK SHARP EDGES.</p>		<p>DWG NO 561073-CU</p>		<p>SCALE .75/1</p>
		<p>SPN- SIMILAR P/N</p>		<p>SHEET 3 OF 3</p>