

1 2 3 4 5 6 7 8

**NOTES:**

1. USE INSTRUCTION SHEET IN91100 FOR ATTACHING DAK TO PXI CARD
2. MATING ITA MODULE P/N 561411.
3. SUPPLIED WITH MOUNTING HARDWARE.
4. SEE SHEET 3 FOR WIRE LIST.

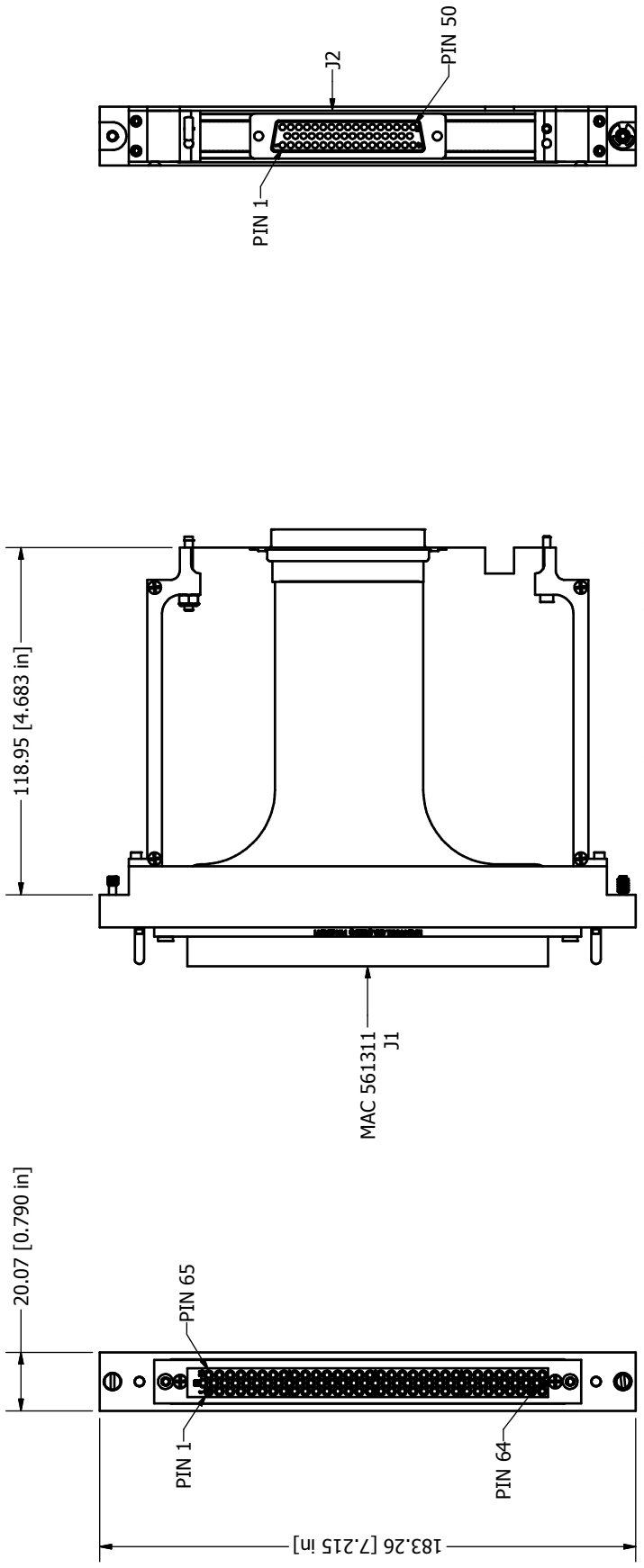

REVISION HISTORY		DATE	APPROVED
REV	DESCRIPTION		
A	RELEASED FOR PRODUCTION	04/01/2008	AO

<p><b>MAC PANEL PROPRIETARY</b> This document may contain confidential and proprietary information that is the property of MAC Panel Company that may not be disclosed to, or duplicated for others except as authorized by MAC Panel Company.</p>	<p>13/02/2008</p>	<p>MAC PANEL COMPANY - HIGH POINT, NC</p>			
<p>DRAWN BY AO ENGINEERING GAC OPERATIONS C. BOGGS MANUFACTURING R. SPIVEY ASSEMBLY</p>	<p>TITLE DAK ASSY, PICK, CABLE, 50P D-SUB FEMALE</p>	<p>SIZE B</p>	<p>DWG NO 561071-CU</p>		
<p>TOLERANCES (UNLESS OTHERWISE SPECIFIED) SHEET METAL MACHINED ANGLES ± 1° ANGLES ± 1° XX ± .03 XX ± .01 .XXX ± .010 .XXX ± .005 .XXX ± .010 .XXX ± .005</p>	<p>THIRD ANGLE PROJECTION</p>	<p>MATERIAL USED</p>	<p>SCALE .75/1 SPN: SIMILAR P/N</p>		
<p><b>BALLOON LEGEND</b></p> <table border="1" style="margin: auto;"> <tr> <td style="width: 50px; height: 20px; border-radius: 10px;">PART NUMBER</td> <td style="width: 50px; height: 20px; border-radius: 10px;">QTY</td> </tr> </table>	PART NUMBER	QTY	<p>SHEET 1 OF 3</p>		
PART NUMBER	QTY				

D C B A

1 2 3 4 5 6 7 8

1 2 3 4 5 6 7 8

**NOTES:**

1. USE INSTRUCTION SHEET IN91100 FOR ATTACHING DAK TO PXI CARD
2. MATING ITA MODULE P/N 561411.
3. SUPPLIED WITH MOUNTING HARDWARE.
4. SEE SHEET 3 FOR WIRE LIST.

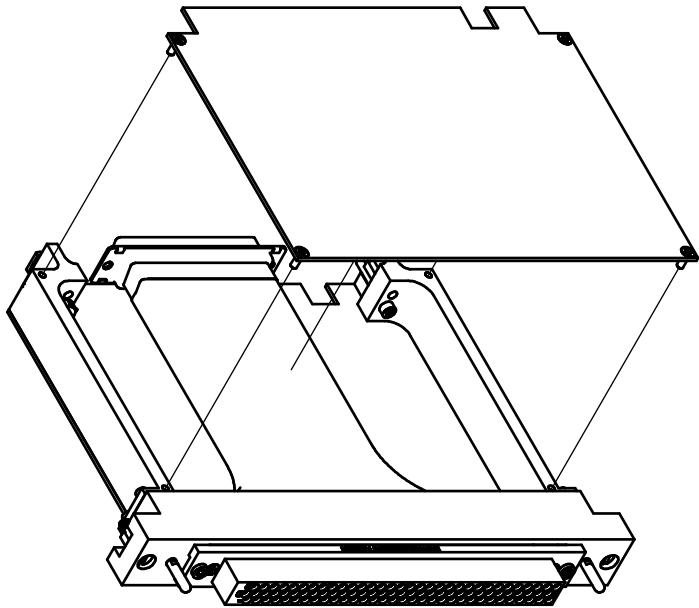

D C B A

BALLOON LEGEND	
PART NUMBER	QTY

MAC PANEL PROPRIETARY  
 This document may contain confidential and proprietary information that is the property of MAC Panel Company that may not be disclosed to, or duplicated for others except as authorized by MAC Panel Company.

DRAWN BY  
 AO  
 ENGINEERING  
 GAC  
 OPERATIONS  
 C. BOGGS  
 MANUFACTURING  
 R. SPIVEY  
 ASSEMBLY  
 MATERIAL USED  
 -

13/02/2008  
 TITLE  
 DAK ASSY,PICK,CABLE,50P D-SUB FEMALE  
 SIZE  
 B  
 SCALE .75/1  
 DWG NO  
 561071-CU  
 SPM- SIMILAR P/N

MAC PANEL PROPRIETARY  
 This document may contain confidential and proprietary information that is the property of MAC Panel Company that may not be disclosed to, or duplicated for others except as authorized by MAC Panel Company.

TOLERANCES (UNLESS OTHERWISE SPECIFIED)  
 SHEET METAL MACHINED  
 ANGLES ± 1° ANGLES ± 1°  
 .XX ± .03 .XX ± .01  
 .XXX ± .010 .XXX ± .005  
 .XXXX ± .005  
 REMOVE ALL BURRS AND BREAK SHARP EDGES.

Third Angle Projection

MAC PANEL COMPANY - HIGH POINT, NC  
 DAK ASSY,PICK,CABLE,50P D-SUB FEMALE  
 SIZE B  
 SCALE .75/1  
 DWG NO 561071-CU  
 SPM- SIMILAR P/N  
 SHEET 2 OF 3

NOTES:

1. USE INSTRUCTION SHEET IN91100 FOR ATTACHING DAK TO PXI CARD
2. MATING ITA MODULE P/N 561411.
3. SUPPLIED WITH MOUNTING HARDWARE.
4. SEE SHEET 3 FOR WIRE LIST.

**561071WL**

MAC 561311 J1	M745253-7 D-SUB J2	MAC 561311 J1	M745253-7 D-SUB J2
1	1	26	26
2	2	27	27
3	3	28	28
4	4	29	29
5	5	30	30
6	6	31	31
7	7	32	32
8	8	33	33
9	9	34	34
10	10	35	35
11	11	36	36
12	12	37	37
13	13	38	38
14	14	39	39
15	15	40	40
16	16	41	41
17	17	42	42
18	18	43	43
19	19	44	44
20	20	45	45
21	21	46	46
22	22	47	47
23	23	48	48
24	24	49	49
25	25	50	50

**BALLOON LEGEND**

PART NUMBER	QTY
-------------	-----

MAC PANEL PROPRIETARY  
This document may contain confidential and proprietary information that is the property of MAC Panel Company that may not be disclosed to, or duplicated for others except as authorized by MAC Panel Company.

TOLERANCES (UNLESS OTHERWISE SPECIFIED)  
SHEET METAL MACHINED  
ANGLES ± 1° ANGLES ± 1°  
XX ± .03 .XX ± .01  
.XXX ± .010 .XXX ± .005  
.XXXX ± .005

REMOVE ALL BURRS AND BREAK SHARP EDGES.



Third Angle Projection

MAC PANEL COMPANY - HIGH POINT, NC

TITLE  
**DAK ASSY,PICK,CABLE,50P D-SUB FEMALE**

SIZE **B** DWG NO **561071-CU**

SCALE .75/1 SPN- SIMILAR P/N

DRAWN BY  
AO  
ENGINEERING  
GAC  
OPERATIONS  
C.BOGGS  
MANUFACTURING  
R.SPIVEY  
ASSEMBLY

13/02/2008