

NOTES:

1. USE INSTRUCTION SHEET IN9110 FOR ATTACHING DAK TO PXI CARD.
2. MATING ITA MODULE P/N 561402.
3. SUPPLIED WITH MOUNTING HARDWARE.
4. SEE SHEET 3 FOR WIRE LIST.

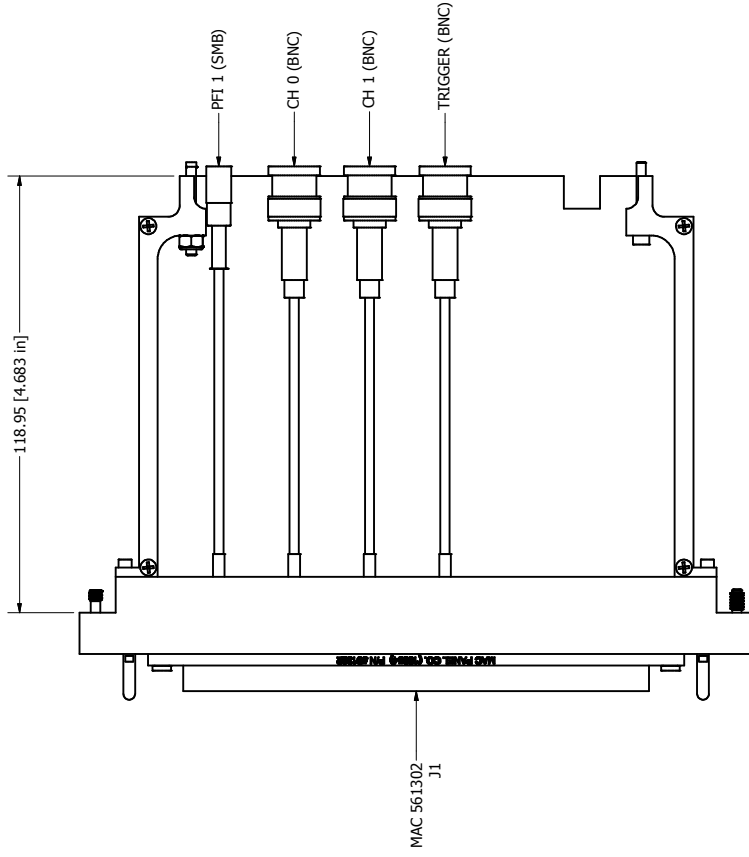

RIGHT SIDE PLATE REMOVED FOR CLARITY.

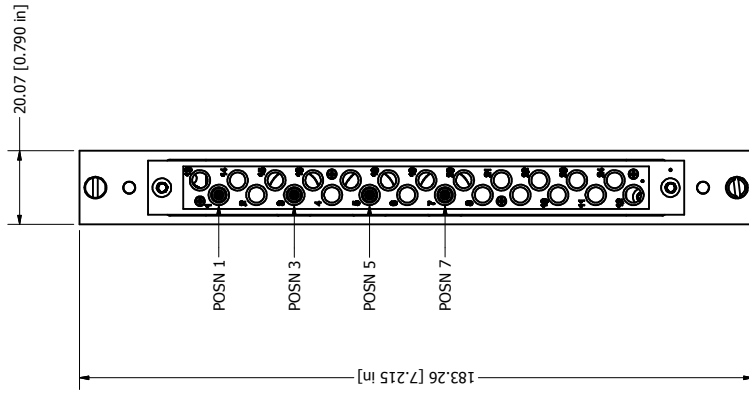

DRAWN BY WIKM ENGINEERING M4		13/04/2007	MAC PANEL COMPANY - HIGH POINT, NC	
OPERATIONS C. BOGGS		18/04/2007	TITLE	
MANUFACTURING R. SPIVEY		18/04/2007	DAK, SCOUT, PXI-5112	
ASSEMBLY			SIZE C	
MATERIAL USED			DWG NO 561042-CU	
			SCALE 1/1	
			SPR: SIMILAR P/N	
			SHEET 1 OF 3	

<p>MAC PANEL PROPRIETARY</p> <p>This document may contain confidential and proprietary information that is the property of MAC Panel Company that may not be disclosed to, or duplicated for others except as authorized by MAC Panel Company.</p>		<p>Third Angle Projection</p>
<p>TOLERANCES (UNLESS OTHERWISE SPECIFIED)</p> <p>SHEET METAL MACHINED</p> <p>ANGLES ± 1°</p> <p>± .03</p> <p>.XX ± .01</p> <p>.XXX ± .010</p> <p>.XXXX ± .005</p>		<p>REMOVE ALL BURRS AND BREAK SHARP EDGES.</p>

BALLOON LEGEND	
PART NUMBER	QTY

NOTES:

1. USE INSTRUCTION SHEET IN9110 FOR ATTACHING DAK TO PXI CARD.
2. MATING ITA MODULE P/N 561402.
3. SUPPLIED WITH MOUNTING HARDWARE.
4. SEE SHEET 3 FOR WIRE LIST.

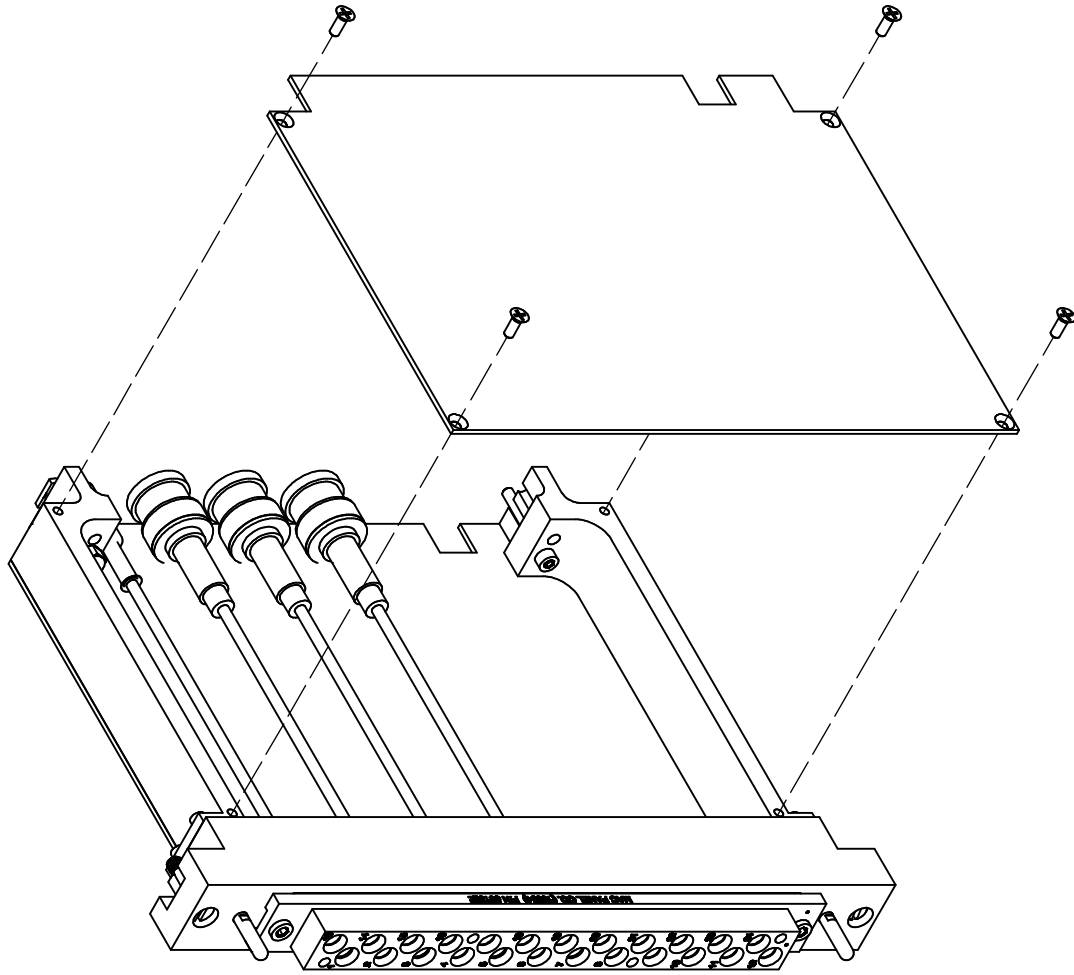

DRAWN BY WJWM ENGINEERING M4		13/04/2007	MAC PANEL COMPANY - HIGH POINT, NC	
OPERATIONS C. BOGGS		18/04/2007	TITLE	
MANUFACTURING R. SPIVEY ASSEMBLY		18/04/2007	DAK, SCOUT, PXI-5112	
MATERIAL USED -			SIZE C	DWG NO 561042-CU
			SCALE 1/1	SPR: SIMILAR P/N
				SHEET 2 OF 3

<p>MAC PANEL PROPRIETARY</p> <p>This document may contain confidential and proprietary information that is the property of MAC Panel Company that may not be disclosed to, or duplicated for others except as authorized by MAC Panel Company.</p>		<p>Third Angle Projection</p>
<p>TOLERANCES (UNLESS OTHERWISE SPECIFIED)</p> <p>SHEET METAL MACHINED</p> <p>ANGLES ± 1°</p> <p>± .03</p> <p>.XX ± .05</p> <p>.XXX ± .10</p>		<p>ANGLES ± 1°</p> <p>± .01</p> <p>.XX ± .05</p> <p>.XXX ± .10</p>
<p>REMOVE ALL BURRS AND BREAK SHARP EDGES.</p>		

BALLOON LEGEND	
PART NUMBER	QTY

NOTES:

1. USE INSTRUCTION SHEET IN9110 FOR ATTACHING DAK TO PXI CARD.
2. MATING ITA MODULE P/N 561402.
3. SUPPLIED WITH MOUNTING HARDWARE.
4. SEE SHEET 3 FOR WIRE LIST.

<b>561042WL</b>			
MAC 561302 J1	10559-01 BNC	MAC 561302 J1	M1313403001 SMB
3	CH0	1	PFI 1
5	CH1		
7	Trig		

**BALLOON LEGEND**

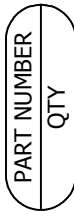

	DRAWN BY WKM ENGINEERING M4	13/04/2007 18/04/2007	MAC PANEL COMPANY - HIGH POINT, NC
	OPERATIONS C. BOGGS	18/04/2007	TITLE
	MANUFACTURING R. SPIVEY	18/04/2007	DAK, SCOUT, PXI-5112
	ASSEMBLY		SIZE C
	MATERIAL USED -		DWG NO 561042-CU
			SCALE 1/1    SPR: SIMILAR P/N

MAC PANEL PROPRIETARY  
This document may contain confidential and proprietary information that is the property of MAC Panel Company that may not be disclosed to, or duplicated for others except as authorized by MAC Panel Company.

TOLEANCES (UNLESS OTHERWISE SPECIFIED)  
SHEET METAL    MACHINED

ANGLES ± 1°    ANGLES ± 1°  
± .01    ± .01  
.XX    .XX  
.XXX ± .010    .XXX ± .005

REMOVE ALL BURRS AND BREAK SHARP EDGES.

Third Angle Projection