

8 | 7 | 6 | 5 | 4 | 3 | 2 | 1

NOTES:

1. USE INSTRUCTION SHEET IN91100 FOR ATTACHING DAK TO PXI CARD
2. MATING ITA MODULE P/N 561411.
3. SUPPLIED WITH MOUNTING HARDWARE.
4. SEE SHEET 3 FOR WIRE LIST.

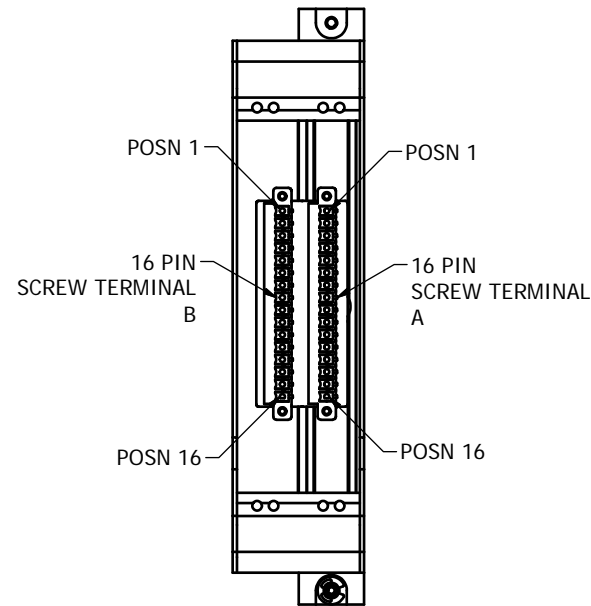
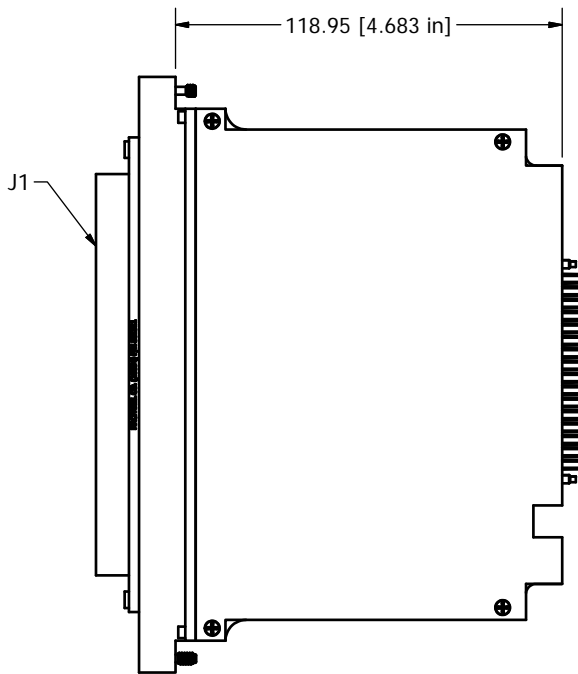
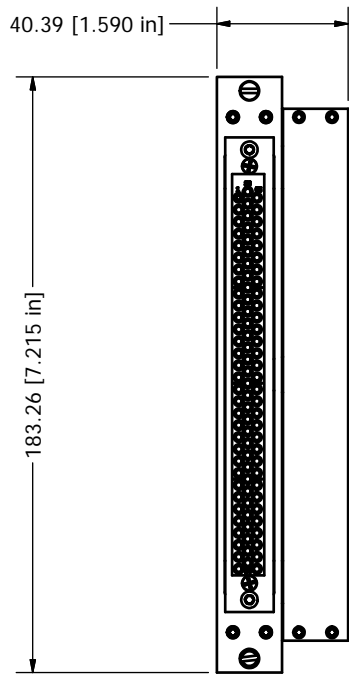

BALLOON LEGEND	
PART NUMBER	QTY

TOLERANCES (UNLESS OTHERWISE SPECIFIED)	
SHEET METAL	MACHINED
ANGLES ± 1°	ANGLES ± 1°
.XX ± .03	.XX ± .01
.XXX ± .010	.XXX ± .005
	.XXXX ± .0005
REMOVE ALL BURRS AND BREAK SHARP EDGES.	

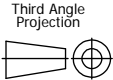

DRAWN BY AO	07/02/2008	MAC PANEL COMPANY - HIGH POINT, NC	
ENGINEERING		TITLE	
OPERATIONS		DAK ASSY, NI, CABLE, PXI-2565	
MANUFACTURING		SIZE B	DWG NO 561030-CU
ASSEMBLY		SCALE 1/1	SPN: SIMILAR P/N
MATERIAL USED -		SHEET 1 OF 2	

8 | 7 | 6 | 5 | 4 | 3 | 2 | 1

NOTES:

1. USE INSTRUCTION SHEET IN91100 FOR ATTACHING DAK TO PXI CARD
2. MATING ITA MODULE P/N 561411.
3. SUPPLIED WITH MOUNTING HARDWARE.
4. SEE SHEET 3 FOR WIRE LIST.

MAC 561311 J1	16 Pin Screw Terminal A	MAC 561311 J1	16 Pin Screw Terminal B
1	1	65	1
2	2	66	2
3	3	67	3
4	4	68	4
5	5	69	5
6	6	70	6
7	7	71	7
8	8	72	8
9	9	73	9
10	10	74	10
11	11	75	11
12	12	76	12
13	13	77	13
14	14	78	14
15	15	79	15
16	16	80	16

**BALLOON LEGEND**

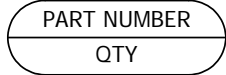

TOLERANCES (UNLESS OTHERWISE SPECIFIED)

SHEET METAL	MACHINED
ANGLES ± 1°	ANGLES ± 1°
.XX ± .03	.XX ± .01
.XXX ± .010	.XXX ± .005
	.XXXX ± .0005

REMOVE ALL BURRS AND BREAK SHARP EDGES.

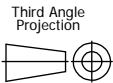

DRAWN BY AO	07/02/2008	MAC PANEL COMPANY - HIGH POINT, NC	
ENGINEERING		TITLE	
OPERATIONS		DAK ASSY, NI, CABLE, PXI - 2565	
MANUFACTURING		SIZE B	DWG NO 561030-CU
ASSEMBLY		SCALE 1/1	SPN: SIMILAR P/N
MATERIAL USED	-	SHEET 2 OF 2	