

BALLOON LEGEND	
PART NUMBER	QTY

TOLERANCES (UNLESS OTHERWISE SPECIFIED)

SHEET METAL:	MACHINED:	Third Angle Projection
XX ± .03 .XXX ± .010	XX ± .01 .XXX ± .005 .XXXX ± .0005	
ANGLES ± 1'	ANGLES ± 1'	

REMOVE ALL BURRS AND BREAK SHARP EDGES.

DRAWN BY	
ENGINEERING	
OPERATIONS	
MANUFACTURING	
ASSEMBLY	
MATERIAL USED	

MAC PANEL COMPANY - HIGH POINT, NC	
TITLE	
DAK ASSY, SCOUT, PXI-2530 (8X16 MATRIX)	
SIZE	DWG NO
C	561025-CU
SCALE	SPN: SIMILAR P/N
1/1	SHEET 1 OF 3

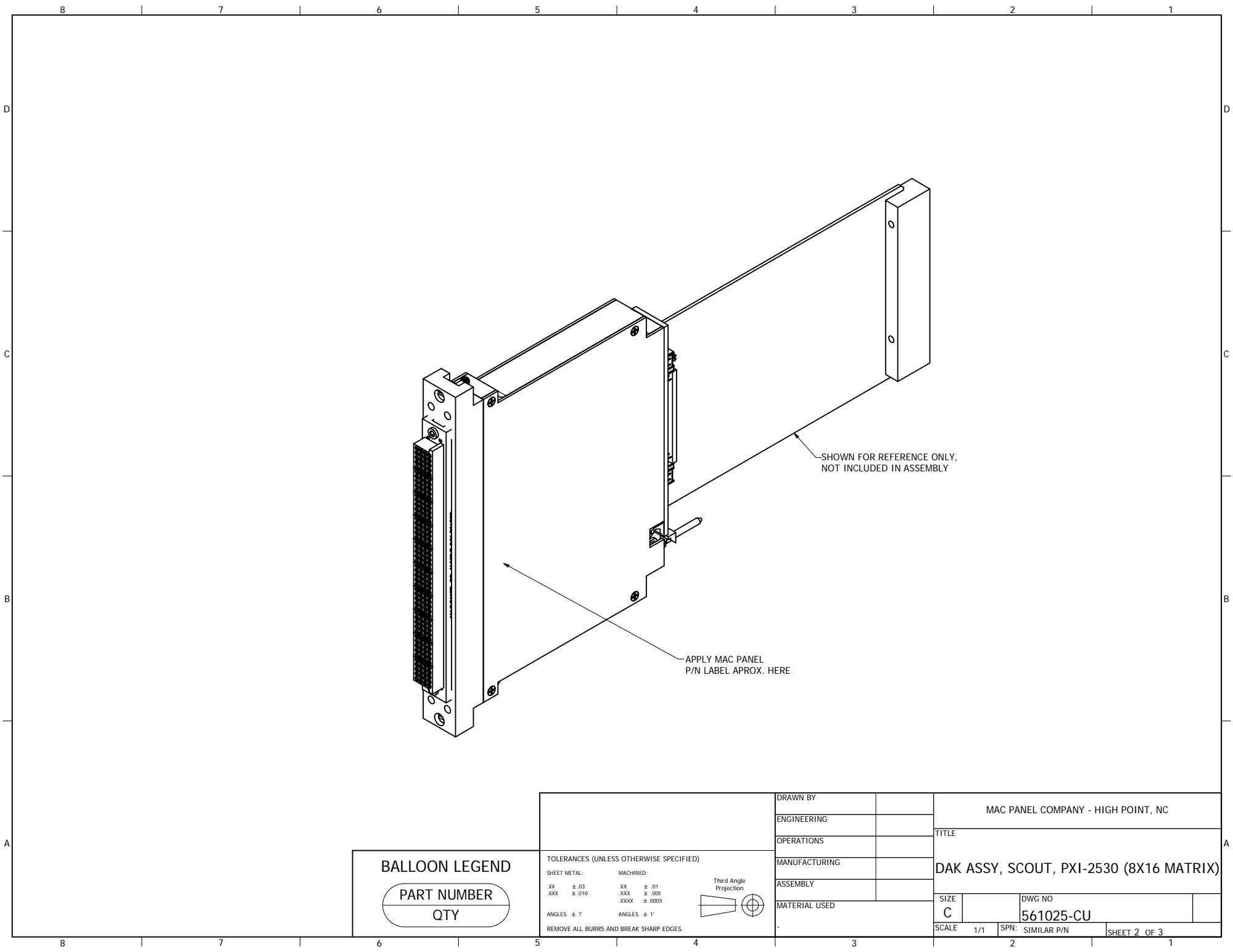

**BALLOON LEGEND**

PART NUMBER
QTY

**TOLERANCES (UNLESS OTHERWISE SPECIFIED)**

SHEET METAL:		MACHINED:	
XX ± .03	XX ± .01	XX ± .01	XX ± .01
.XXX ± .010	.XXX ± .005	.XXX ± .005	.XXX ± .005
.XXXX ± .005	.XXXX ± .0005	.XXXX ± .0005	.XXXX ± .0005
ANGLES ± 1°	ANGLES ± 1°	ANGLES ± 1°	ANGLES ± 1°

REMOVE ALL BURRS AND BREAK SHARP EDGES.



DRAWN BY	
ENGINEERING	
OPERATIONS	
MANUFACTURING	
ASSEMBLY	
MATERIAL USED	

MAC PANEL COMPANY - HIGH POINT, NC	
TITLE	
DAK ASSY, SCOUT, PXI-2530 (8X16 MATRIX)	
SIZE	DWG NO
C	561025-CU
SCALE	SPN: SIMILAR P/N
1/1	SHEET 2 OF 3

D  
C  
B  
A

D  
C  
B  
A

561025WL SCOUT DAK LIST 561025WL

MAC DAK 561025	TB-2632 COLUMNS	MAC DAK 561025	TB-2631 ROWS	MAK DAK 561025	TB-2632 Wire ref	561025	TB2632 GND/TRIG
A 1	0	B 1	0	C 1	0	D 1	Gnd
A 2	1	B 2	1	C 2	1	D 2	TRIGIN
A 3	2	B 3	2	C 3	2	D 3	GND
A 4	3	B 4	3	C 4	3	D 4	TRIGOUT
A 5	4	B 5	4				
A 6	5	B 6	5				
A 7	6	B 7	6				
A 8	7	B 8	7				
A 9	8						
A 10	9						
A 11	10						
A 12	11						
A 13	12						
A 14	13						
A 15	14						
A 16	15						

BALLOON LEGEND

PART NUMBER  
QTY

TOLERANCES (UNLESS OTHERWISE SPECIFIED)

SHEET METAL:      MACHINED:  
 XX ± .03            XX ± .01  
 .XXX ± .010        .XXX ± .005  
 .XXXX ± .0005

ANGLES ± 1'      ANGLES ± 1'

REMOVE ALL BURRS AND BREAK SHARP EDGES.



DRAWN BY		MAC PANEL COMPANY - HIGH POINT, NC
ENGINEERING		TITLE DAK ASSY, SCOUT, PXI-2530 (8X16 MATRIX)
OPERATIONS		
MANUFACTURING		
ASSEMBLY		
MATERIAL USED		SIZE C
		DWG NO 561025-CU
		SCALE 1/1    SPN: SIMILAR P/N    SHEET 3 OF 3