

NOTES:

1. USE INSTRUCTION SHEET IN91100 FOR ATTACHING DAK TO PXI CARD.
2. RECEIVER/ITA MODULE TO BE KEYED ON LEFT SIDE.
3. MATING ITA MODULE P/N 604013.
4. WIRE PER 561023WL WIRELIST.
5. BAG AND TAG P/N 5510941, 5510991, 440E9230.
6. INSTALL P/N 5510530 2X AND 256D45 4X USING P/N 10589-02 PURPLE LOCTITE #222 AS INDICATED.

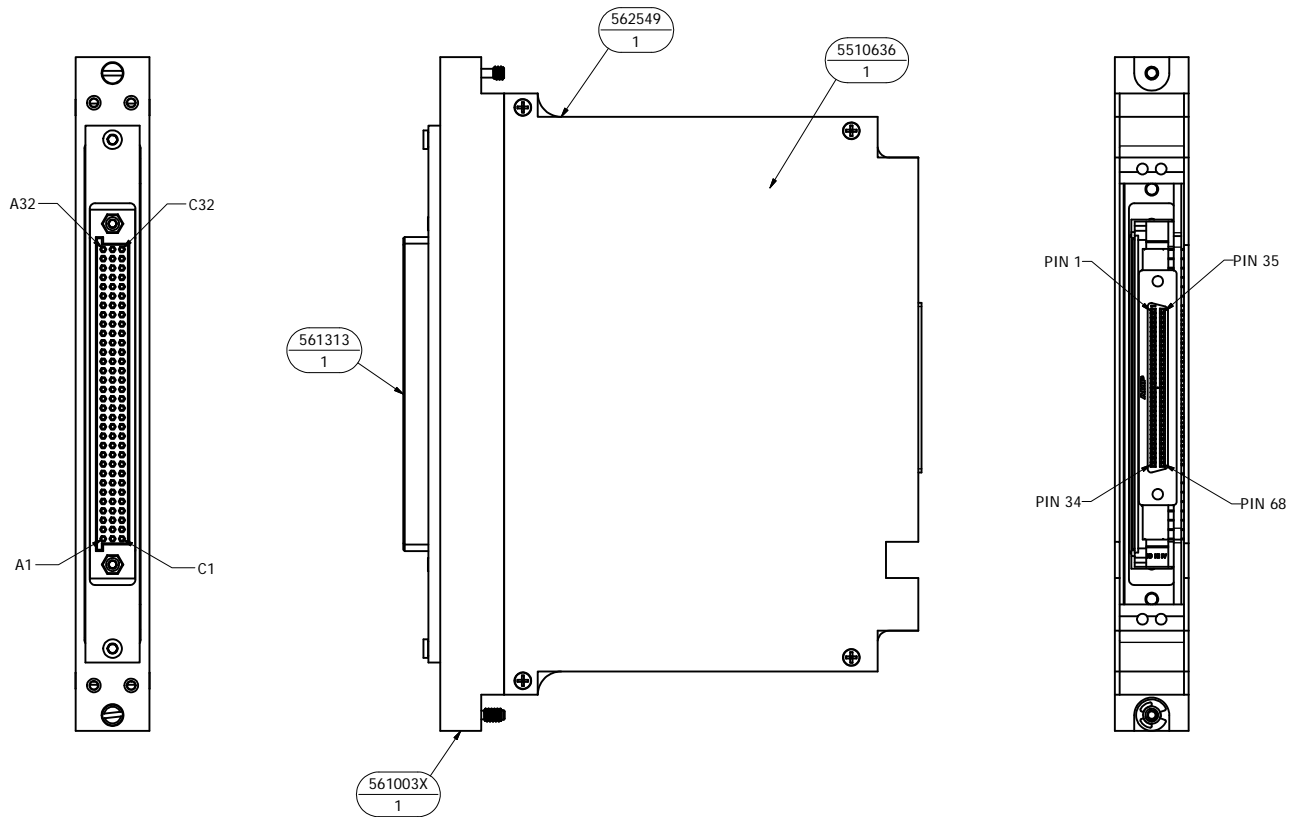

BALLOON LEGEND	
PART NUMBER	QTY

MAC PANEL PROPRIETARY  
 This document may contain confidential and proprietary information that is the property of MAC Panel Company that may not be disclosed to, or duplicated for others except as authorized by MAC Panel Company.

TOLERANCES (UNLESS OTHERWISE SPECIFIED)

SHEET METAL	MACHINED
ANGLES ± 1°	ANGLES ± 1°
.XX ± .03	.XX ± .01
.XXX ± .010	.XXX ± .005
	.XXX ± .0005

REMOVE ALL BURRS AND BREAK SHARP EDGES.

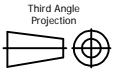

DRAWN BY	16/04/2007
WKM	
ENGINEERING	
M4	16/04/2007
OPERATIONS	
C. BOGGS	16/04/2007
MANUFACTURING	
R. SPIVEY	16/04/2007
ASSEMBLY	
MATERIAL USED	
-	

MAC PANEL COMPANY - HIGH POINT, NC	
TITLE	
SCOUT, DAK, 68 PIN SCS12	
SIZE	DWG NO
C	561023-CU
SCALE	SPN: SIMILAR P/N
1/1	SHEET 1 OF 3

QTY
1
1
1
1
1

NOTES:

1. USE INSTRUCTION SHEET IN91100 FOR ATTACHING DAK TO PXI CARD.
2. RECEIVER/ITA MODULE TO BE KEYED ON LEFT SIDE.
3. MATING ITA MODULE P/N 604013.
4. WIRE PER 561023WL WIRELIST.
5. BAG AND TAG P/N 5510941, 5510991, 440E9230.
6. INSTALL P/N 5510530 2X AND 256D45 4X USING P/N 10589-02 PURPLE LOCTITE #222 AS INDICATED.

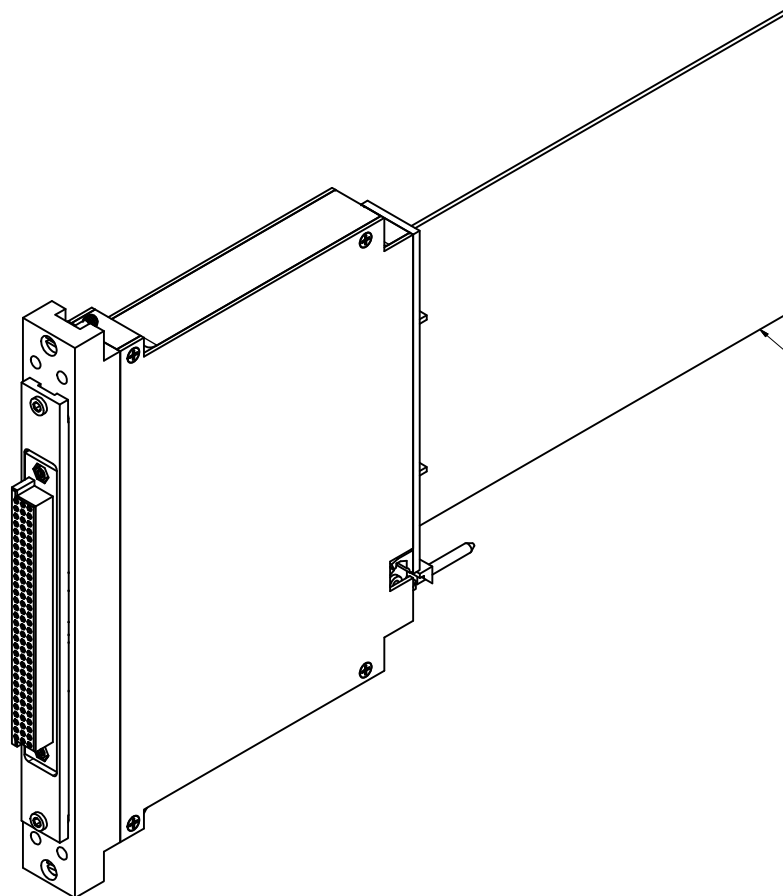

— SHOWN FOR REFERENCE ONLY,  
NOT INCLUDED IN ASSEMBLY

BALLOON LEGEND	
PART NUMBER	QTY

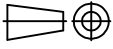
MAC PANEL PROPRIETARY This document may contain confidential and proprietary information that is the property of MAC Panel Company that may not be disclosed to, or duplicated for others except as authorized by MAC Panel Company.		DRAWN BY	16/04/2007	MAC PANEL COMPANY - HIGH POINT, NC	
		WKM ENGINEERING	16/04/2007		
TOLERANCES (UNLESS OTHERWISE SPECIFIED) SHEET METAL    MACHINED ANGLES ± 1'    ANGLES ± 1'		OPERATIONS	16/04/2007	TITLE SCOUT, DAK, 68 PIN SCS12	
		C.BOGGS MANUFACTURING	16/04/2007		
Third Angle Projection  REMOVE ALL BURRS AND BREAK SHARP EDGES.		R.SPIVEY ASSEMBLY	16/04/2007	SIZE	DWG NO
		MATERIAL USED		C	561023-CU
		SCALE	1/1	SPN: SIMILAR P/N	SHEET 2 OF 3

NOTES:

1. USE INSTRUCTION SHEET IN91100 FOR ATTACHING DAK TO PXI CARD.
2. RECEIVER/ITA MODULE TO BE KEYED ON LEFT SIDE.
3. MATING ITA MODULE P/N 604013.
4. WIRE PER 561023WL WIRELIST.
5. BAG AND TAG P/N 5510941, 5510991, 440E9230.
6. INSTALL P/N 5510530 2X AND 256D45 4X USING P/N 10589-02 PURPLE LOCTITE #222 AS INDICATED.

MAC 96 PIN CONNECTOR	68 PIN SCSI CONNECTOR	MAC 96 PIN CONNECTOR	68 PIN SCSI CONNECTOR	MAC 96 PIN CONNECTOR	68 PIN SCSI CONNECTOR
A2	33	B1	68	C1	34
A4	32	B2	31	C2	67
A5	65	B4	30	C4	66
A6	64	B5	63	C5	29
A8	27	B6	62	C6	28
A9	26	B8	25	C8	61
A10	59	B9	24	C9	60
A12	58	B10	57	C10	23
A13	21	B12	56	C12	22
A14	20	B13	19	C13	55
A16	53	B14	18	C14	54
A17	52	B16	51	C16	17
A18	15	B17	50	C17	16
A20	14	B18	13	C18	49
A21	47	B20	12	C20	48
A22	46	B21	45	C21	11
A24	9	B22	44	C22	10
A25	8	B24	7	C24	43
A26	41	B25	6	C25	42
A28	40	B26	39	C26	5
A29	38	B28	4	C28	3
A30	1	B29	37	C29	2
		B30	36	C30	35

**BALLOON LEGEND**

PART NUMBER
QTY

MAC PANEL PROPRIETARY  
This document may contain confidential and proprietary information that is the property of MAC Panel Company that may not be disclosed to, or duplicated for others except as authorized by MAC Panel Company.

TOLERANCES (UNLESS OTHERWISE SPECIFIED)

SHEET METAL	MACHINED
ANGLES ± 1°	ANGLES ± 1°
.XX ± .03	.XX ± .01
.XXX ± .010	.XXX ± .005
	.XXX ± .0005

Third Angle Projection

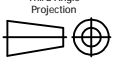

REMOVE ALL BURRS AND BREAK SHARP EDGES.

DRAWN BY	16/04/2007
WKM	
ENGINEERING	16/04/2007
M4	
OPERATIONS	16/04/2007
C. BOGGS	
MANUFACTURING	16/04/2007
R. SPIVEY	
ASSEMBLY	
MATERIAL USED	
-	

MAC PANEL COMPANY - HIGH POINT, NC	
TITLE	
SCOUT, DAK, 68 PIN SCSI2	
SIZE	DWG NO
C	561023-CU
SCALE	1/1
SPN:	SIMILAR P/N
SHEET 3 OF 3	