

REVISION HISTORY			
REV	DESCRIPTION	DATE	APPROVED
A	RELEASE FOR PRODUCTION	4/16/2009	AO

NOTES:

1. USE INSTRUCTION SHEET IN9110 FOR ATTACHING DAK TO PXI CARD.
2. MATING ITA MODULE P/N 561401.
3. SUPPLIED WITH MOUNTING HARDWARE.
4. SEE SHEET 3 FOR WIRE LIST.

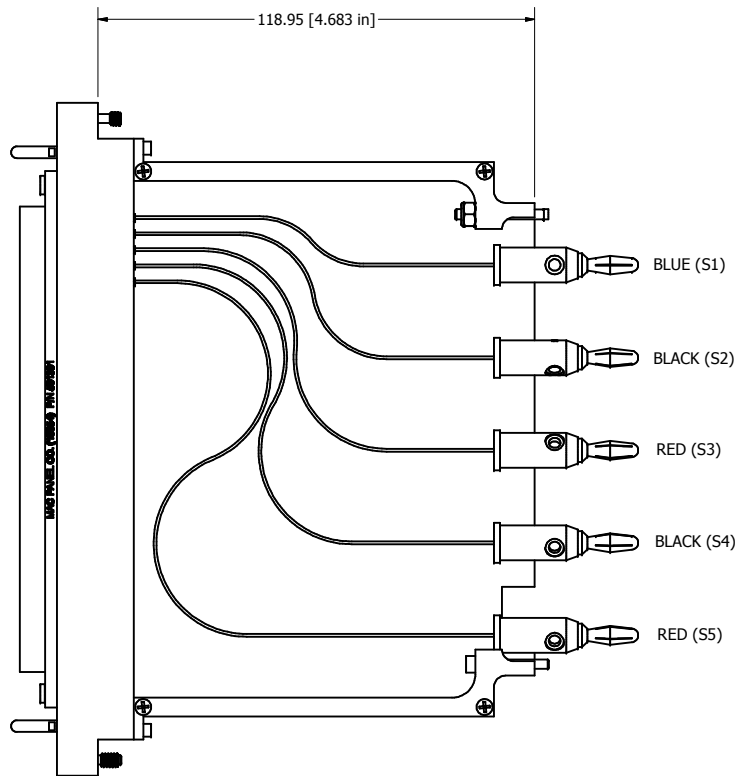
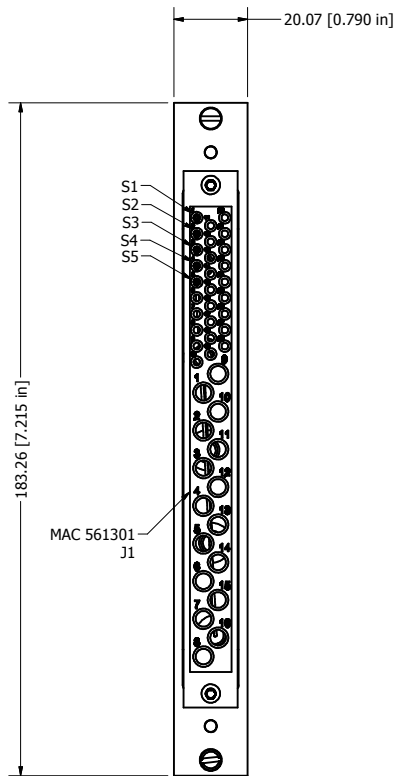

BANANA PLUGS
TO PXI-4022

RIGHT SIDE PANEL REMOVED FOR CLARITY.

BALLOON LEGEND	
PART NUMBER	QTY

MAC PANEL PROPRIETARY
This document may contain confidential and proprietary information that is the property of MAC Panel Company that may not be disclosed to, or duplicated for others except as authorized by MAC Panel Company.

TOLERANCES (UNLESS OTHERWISE SPECIFIED)

SHEET METAL	MACHINED
ANGLES ± 1'	ANGLES ± 1'
.XX ± .03	.XX ± .01
.XXX ± .010	.XXX ± .005
	.XXX ± .0005

REMOVE ALL BURRS AND BREAK SHARP EDGES.

Third Angle Projection

DRAWN BY AO	14/04/2009	MAC PANEL COMPANY - HIGH POINT, NC	
ENGINEERING GAC		TITLE	
OPERATIONS C.BOGGS		DAK ASSY, SCOUT, PXI-4022	
MANUFACTURING R.SPIVEY		SIZE C	DWG NO 561141-cu
ASSEMBLY		SCALE 1/1	SPN: SIMILAR P/N
MATERIAL USED -		SHEET 1 OF 3	

NOTES:

1. USE INSTRUCTION SHEET IN9110 FOR ATTACHING DAK TO PXI CARD.
2. MATING ITA MODULE P/N 561401.
3. SUPPLIED WITH MOUNTING HARDWARE.
4. SEE SHEET 3 FOR WIRE LIST.

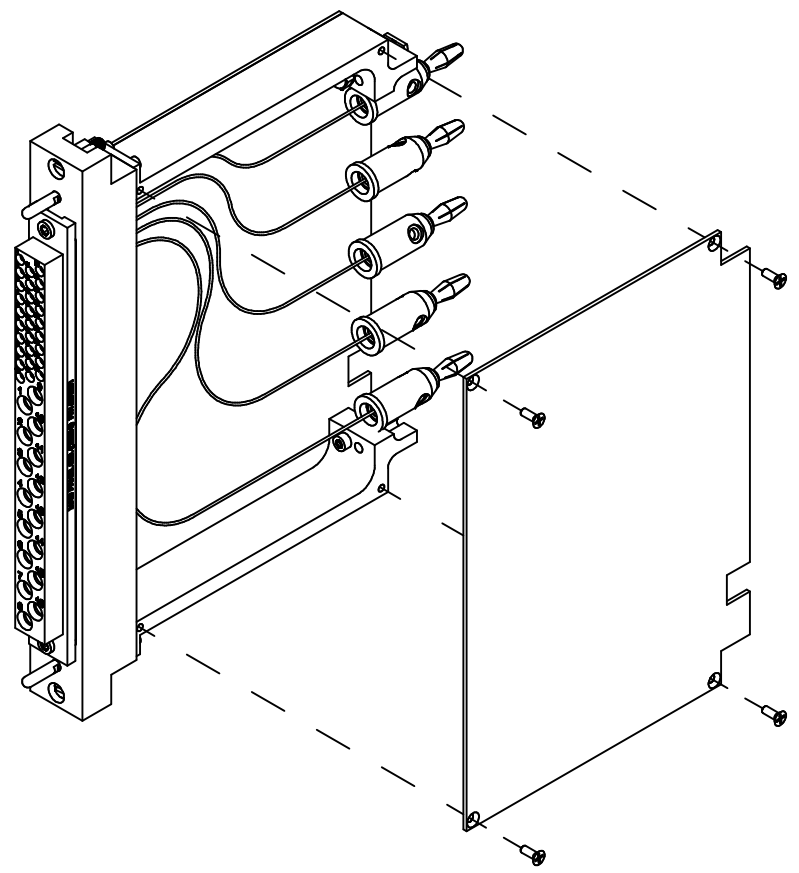

D
C
B
A

D
C
B
A

BALLOON LEGEND	
PART NUMBER	QTY

MAC PANEL PROPRIETARY
This document may contain confidential and proprietary information that is the property of MAC Panel Company that may not be disclosed to, or duplicated for others except as authorized by MAC Panel Company.

TOLERANCES (UNLESS OTHERWISE SPECIFIED)

SHEET METAL	MACHINED
ANGLES ± 1'	ANGLES ± 1'
.XX ± .03	.XX ± .01
.XXX ± .010	.XXX ± .005
	.XXX ± .0005

REMOVE ALL BURRS AND BREAK SHARP EDGES.

Third Angle Projection

DRAWN BY	14/04/2009
AO	
ENGINEERING	
GAC	
OPERATIONS	
C.BOGGS	
MANUFACTURING	
R.SPIVEY	
ASSEMBLY	
MATERIAL USED	
-	

MAC PANEL COMPANY - HIGH POINT, NC	
TITLE	
DAK ASSY, SCOUT, PXI-4022	
SIZE	DWG NO
C	561141-cu
SCALE	SPN: SIMILAR P/N
1/1	SHEET 2 OF 3

NOTES:

1. USE INSTRUCTION SHEET IN9110 FOR ATTACHING DAK TO PXI CARD.
2. MATING ITA MODULE P/N 561401.
3. SUPPLIED WITH MOUNTING HARDWARE.
4. SEE SHEET 3 FOR WIRE LIST.

MAC 561301 J1	Banana Plugs PXI-4022
S1	Blue
S2	Black
S3	Red
S4	Black
S5	Red

BALLOON LEGEND

PART NUMBER
QTY

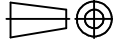
MAC PANEL PROPRIETARY This document may contain confidential and proprietary information that is the property of MAC Panel Company that may not be disclosed to, or duplicated for others except as authorized by MAC Panel Company.		DRAWN BY AO ENGINEERING GAC OPERATIONS C.BOGGS MANUFACTURING R.SPIVEY ASSEMBLY	14/04/2009	MAC PANEL COMPANY - HIGH POINT, NC	
TOLERANCES (UNLESS OTHERWISE SPECIFIED) SHEET METAL MACHINED ANGLES ± 1' ANGLES ± 1'		Third Angle Projection 		TITLE DAK ASSY, SCOUT, PXI-4022	
.XX ± .03 .XX ± .01 .XXX ± .010 .XXX ± .005 .XXX ± .0005 .XXX ± .0005		MATERIAL USED -		SIZE C	DWG NO 561141-cu
REMOVE ALL BURRS AND BREAK SHARP EDGES.		SCALE 1/1	SPN: 2	SIMILAR P/N	SHEET 3 OF 3